



DIRECTIONAL WELL DESIGN, TRAJECTORY AND SURVEY CALCULATIONS, WITH A CASE STUDY IN FIALE, ASAL RIFT, DJIBOUTI

Farah Omar Farah

Ministry of Energy and Natural Resources

P.O. Box 10010

Djibouti

DJIBOUTI

farahwalioullah@gmail.com

ABSTRACT

Djibouti plans to drill 4 new geothermal wells for its future production in the Lava Lake or Fialé, within the Asal Rift segment. These wells are planned to be directionally drilled and the targets are based on six previous wells (Asal 1 - 6) drilled in the late 1980s in this rift segment. These 6 wells were drilled in an area which has high temperature potential, but problems of low permeability and high salinity were encountered. This paper presents directional well planning for these new wells and calculations for: (a) the trajectory and survey, (b) the well path, (c) the vertical depth. Two case studies are presented for Fialé and the resulting well path, using the build and hold type of directional wells. A simple BHA with two-stabilizers is proposed with an optimal weight on bit. Based on the casing plan, the kick-off point should be lowered to 430 m depth rather than 350 m as proposed by the pre-feasibility study, which is about 30 m below the casing shoe of the intermediate casing. Another option is drilling vertical wells, which would provide the same subsurface information as directional wells. However, a thorough cost analysis of drilling, survey tools, and equipment is needed to determine whether directional or vertical drilling is financially advantageous for the exploration wells. Directional drilling would not require new permitting or much geological and geophysical studies as such studies were done in the pre-feasibility phase in 2008. Drilling pads and targets for vertical drilling would, however, require further studies and a permit to drill inside of Fialé crater.

1. INTRODUCTION

Directionally drilled wells represent an efficient way to reach special targets that are difficult to reach using vertically drilled wells. A drawback of directional drilling is higher cost, but the advantage is that surface construction may be minimized while still reaching the intended targets. The main factor in the cost of a directional well is the horizontal distance to the target. The objective of the present study is to present the calculations that show the well path in a 3D space, and to develop the model that gives the minimum drilling length for these wells. The project of constructing and operating a geothermal power plant is divided into four phases from the exploration phase to production. The Asal project is currently in the exploration phase, which involves drilling four exploration and appraisal wells, followed by a

resource appraisal period, and finally by drilling seven to nine additional production wells. Information attained through the drilling of the exploration wells and during the appraisal of the second phase will be used for the conceptual design of the power plant. The true vertical depth (TVD) departure from the end of the built section, and the well path in a build and hold well profile is calculated.

Although the focus of this work is directional drilling, vertical drilling should not be excluded as a perfectly viable option. Therefore, this topic is also presented in a separate section and compared with directional drilling.

1.1 Background

The objective of steering a well trajectory in the right direction and hitting a geological target many kilometers downhole has forced the drilling industry to really focus on tools and methods to identify wellbore location and its path during drilling. In the early days of drilling exploration, it was common to set the drilling rig right above the target and drill a vertical well into it. Later, it became necessary to drill wells to reach targets that were deviated from the reference location at the surface. Throughout the years, many tools and methods have been developed for directional drilling. There are several companies offering tools to deflect and steer wellbores in the right direction and to measure wellbore inclination and azimuth.

The directional survey measurements are given in terms of inclination, azimuth and 3D coordinates, TVD, northing and easting at the depth of the survey station. For many applications, the accurate position and direction of the borehole should be determined at depths which may not coincide with the depth of survey stations. A mathematical tool for interpolating between survey stations is then required.

1.2 Objective

The objective of this paper is to show the calculation methods needed for directional well path design and to show the usage of trajectory and survey calculation methods by designing the well path of two wells in Asal Fialé. The emphasis is on the following:

- Calculate the true vertical depth (TVD) and departure from the vertical, at the end of the build-up (EOB) section and the total depth (TD) to the bottom of the hole, in a build and hold well profile.
- Calculate directional coordinates.
- Describe formulas used to describe and calculate the well trajectory for different methods: Tangential; balanced tangential; average angle; radius of curvature; and minimum curvature.
- Outline the procedure for calculating survey results.
- Calculate the northing, easting, TVD, vertical section and dogleg severity of a survey station using the minimum curvature method.
- Determine the exact bottom hole location of the well.
- Monitor the actual well path while drilling to ensure the target is reached.
- Orient deflection tools (such as directional drilling assemblies) in the required direction when making corrections to the well path.
- Design the bottom hole assembly (BHA) including the buoyed weight (or hook load) in a vertical hole and the required BHA weight in air.

1.3 Scope

The minimum curvature method was chosen for trajectory calculations of the well. The scope of this work is based on:

- Literature review on directional drilling and survey calculation methods; and
- Trajectory and survey calculations methods.

1.4 Literature review

The following directional drilling methods are covered in the following books: *Applied drilling engineering* by Bourgoyne, Millhem, Chenevert, and Young (1991); *Directional drilling and deviation control technology* by the French Oil and Gas Industry Association (1990); and *Directional drilling* by Inglis (1987). Other references are indicated where used. It is pertinent to note that this literature is focused towards petroleum drilling practices. Other sources are:

- 1957: J.E. Edison presents the average angle method;
- 1968: G.J. Wilson presents the radius of curvature method;
- 1971: J.E. Walstrom presents the balanced tangential method;
- 1973: W.A. Zaremba presents the minimum curvature method;
- 1991: Xiushan Liu presents the constant curvature method;
- 1994: Wong et al., and Morita and Whitebay elaborate on the design of wells.
- 2004: S.J. Sawaryn and J.L. Thorogood present their SPE paper named *A compendium of directional calculations using the minimum curvature method*.

2. DIRECTIONAL WELL DESIGN

2.1 Directional drilling

Directional drilling is described as the deflection of a wellbore in order to reach a pre-determined objective below the surface of the earth". Figure 1 shows the main parameters of a directional well.

2.1.1 Definitions and terminology

Directional drilling is the methodology for directing a wellbore along a predetermined trajectory to a target. Vertical wells are usually defined as wells with an inclination within 5° . Wells with an inclination greater than 60° are referred to as highly deviated wells. Wells with a section having an inclination greater than 85° for a significant distance are called horizontal wells. The following terminology is used:

- *Azimuth*: The angle ($^\circ$) between the north direction and the plane containing the vertical line through the wellhead and the vertical line through the target.
- *Build-up rate*: The angle from the kick-off point is steadily built up. This is the build-up phase. The build-up rate ($^\circ/30$ m) is the rate at which the angle is built.
- *Drop-off point*: The depth where the hole angle begins to drop off (i.e. tending to vertical).
- *Displacement*: The horizontal distance between the vertical lines passing through the target and the wellhead.
- *Inclination*: Angle ($^\circ$) made by the tangential section of the hole with the vertical.
- *Kick-off point (KOP)*: The depth at which the well is first deviated from the vertical.
- *Measured depth (MD)*: Depth (length) of the well along the well path.

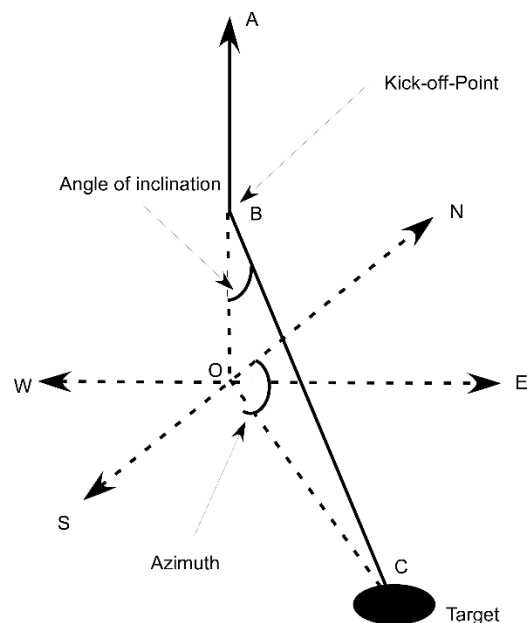

FIGURE 1: Measurement parameters of a directional well (modified from Gabolde and Nguyen, 1991)

- *Tangent section*: Section of a well where the well path is maintained at a certain inclination, with the intent of advancing in both TVD and vertical section. Short tangential sections are built for housing submersible pumps for example.
- *True-vertical depth (TVD)*: Vertical distance between *kelly bushing (KB)* and survey point.
- *Vertical Section (VS)*: Pre-defined azimuth angle along which the VS is calculated, usually the angle between north and a line uniting the wellhead and the total depth, measured on a plan view.
- *Well path*: The trajectory of a directionally drilled well in three dimensions.

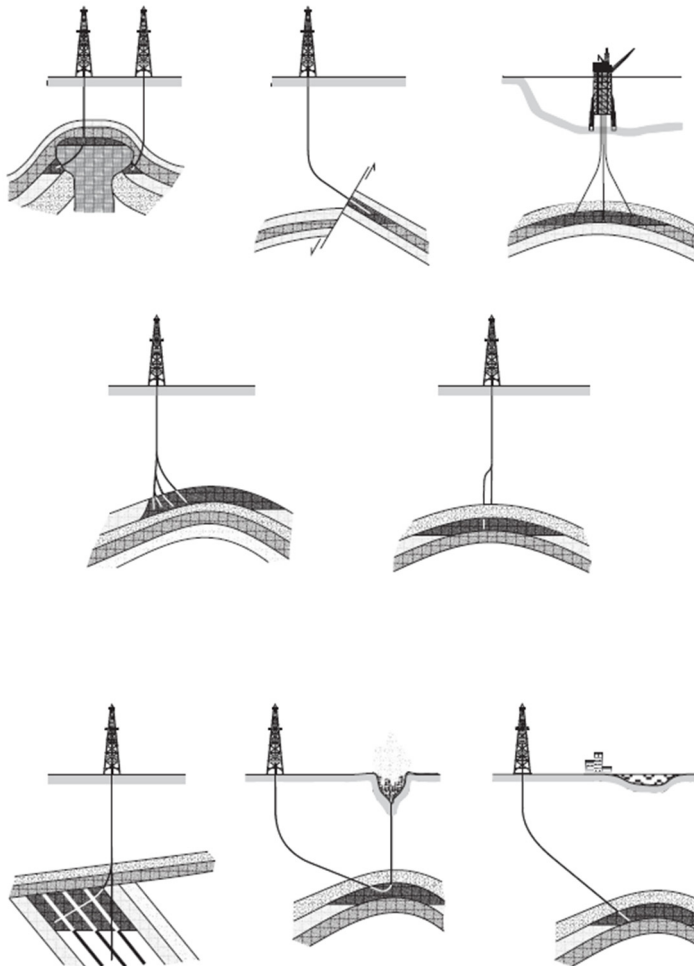

FIGURE 2: Several applications of directional drilling as common in the oil industry (Bourgoyne at al., 1991)

potential for damaging the casing can be minimized by drilling parallel to a fault and then changing the direction of the well to cross the fault into the target.

c) Inaccessible locations. Vertical access to a producing zone is often obstructed by some obstacle at the surface (e.g. river estuary, mountain range, city). In this case, the well may be directionally drilled into the target from a rig site some distance away from the point vertically above the required point of entry into the reservoir.

d) Side-tracking and straightening. It is, in fact, quite difficult to control the angle of inclination of any well (vertical or deviated) and it may be necessary to ‘correct’ the course of the well for many reasons. For example, it may be necessary in the event of the drillpipe becoming stuck in the hole to simply drill around the stuck pipe (or fish), or plug back the well to drill to an alternate target.

2.1.2 Application

The directional well is planned along a predetermined trajectory to hit a subsurface target. The target may be geometric and even adjusted in real time based on *logging while drilling (LWD)* measurements.

There are many reasons for drilling a non-vertical (deviated) well. Some typical applications of directionally controlled drilling are shown in Figure 2.

a) Multi-well platform drilling is widely employed in the North Sea. The development of these fields is only economically feasible if it is possible to drill a large number of wells (up to 40 or 60) from one location (platform) without moving it. The deviated wells are designed to intercept a reservoir over a wide area. Many oil fields (both onshore and offshore) would not be economically feasible without directional drilling.

b) Fault drilling. When a well is drilled across a fault, the casing may be damaged by fault slippage. The

e) *Salt dome drilling.* Salt domes (called diapirs) often form hydrocarbon traps in what were overlying reservoir rocks. In this form of trap, the reservoir is located directly beneath the flank of the salt dome. To avoid potential drilling problems in the salt (e.g. severe washouts, moving salt, high pressure blocks of dolomite) a directional well can be used to drill alongside the diapir (not vertically down through it) and then at an angle below the salt to reach the reservoir.

f) *Relief wells.* If a blow-out occurs and the rig is damaged, or destroyed, it may be possible to kill the “wild” well by drilling another directionally drilled well (relief well) to intercept or pass within a few feet of the bottom of the “wild” well. The “wild” well is killed by circulating high density fluid down the relief well, into and up the wild well.

2.1.3 Directional well types

There are several types of wellbore profiles. Below there is a description and an illustration of the most common profiles:

- *Build and hold profile* (Type 1) is the most common and simplest. The well is vertical until the KOP where it is kicked off and an angle is built. When the desired inclination is reached, the well path is kept tangent or straight until the target is reached.
- *Build, hold and drop profile* (Type 2), also called *shaped wells*, is the same in the upper section as the build and hold well profile. The well is kept vertical until KOP and an inclination is built and the tangent section is drilled. After the tangent section, a drop-off section is drilled where the inclination is reduced and the well path is almost vertical as it hits the target.
- *Deep build/kick-off* (Type 3) is a type of wellbore drilled when there is a hindrance, such as a salt dome, or when the well has to be side-tracked. The well is drilled vertically to a deep KOP and then inclination is built quickly to the target. Horizontal well profile and Horizontal Drain hole well profile are other types of wellbore trajectories. Theoretically, there are more than ten types of wellbore profiles.

These well trajectories are shown in Figure 3.

2.2 Planning the well profile

The first step in planning a directional well is to design the wellbore path, or trajectory, to intersect a given target. The initial design should consider the various types of paths that can be drilled economically.

2.2.1 Parameters defining the well path

There are three specific parameters which must be considered when planning one of the trajectories shown in Figure 3. These parameters combine to define the trajectory of the well:

- *Kick-off point*, is the long hole measured depth at which a change in inclination of the well is initiated and the well is oriented in a particular direction (in terms of north, south, east and west). In general, the most distant targets have the shallowest KOPs in order to reduce the inclination of the tangent section of the well (Figure 3). It is generally easier to kick off a well in shallow formations than in deep formations. The kick-off should also be initiated in formations which are stable and not likely to cause drilling problems, such as unconsolidated clays.
- *Build-up and drop off rate* (in degrees of inclination) are the rates at which the well deviates from the vertical (usually measured in degrees per 30 m or 100 ft). The build-up rate is chosen on the basis of previous drilling experience in the location and the tools available, but rates between 1° and 3° per 30 m or 100 ft of hole drilled are most common in conventional wells. Since the build-

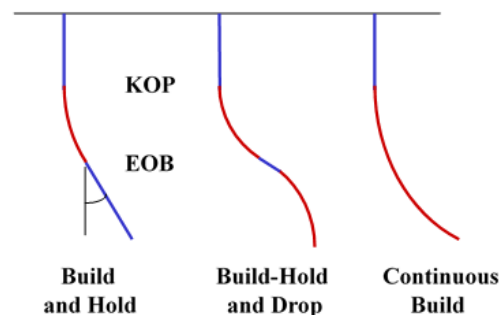

FIGURE 3: Most common types of wellbore profiles

up and drop off rates are constant, these sections of the well, by definition, form the arc of a circle. Build up rates in excess of $3^\circ/30$ m are likely to cause doglegs when drilling conventional deviated wells with conventional drilling equipment. The build-up rate is often termed the dogleg severity (DLS).

- *Tangent angle* of the well (or drift angle) is the inclination (in degrees from the vertical) of the long straight section of the well after the build-up section of the well. This section of the well is termed the tangent section because it forms a tangent to the arc formed by the build-up section of the well. The tangent angle will generally be between 10° and 60° since it is difficult to control the trajectory of the well at angles below 10° and it is difficult to run wire line tools into wells at angles greater than 60° .

2.2.2 Target and geography

The trajectory of a deviated well must be carefully planned so that the most efficient trajectory is used to drill between the rig and the target location and ensure that the well is drilled for the lowest cost. When planning, and subsequently drilling the well, the position of all points along the well-path trajectory is considered in three dimensions (Figure 4). This means that the position of all points on the trajectory must be expressed with respect to a three dimensional reference system. The three dimensional system that is generally used to define the position of a particular point along the well path is:

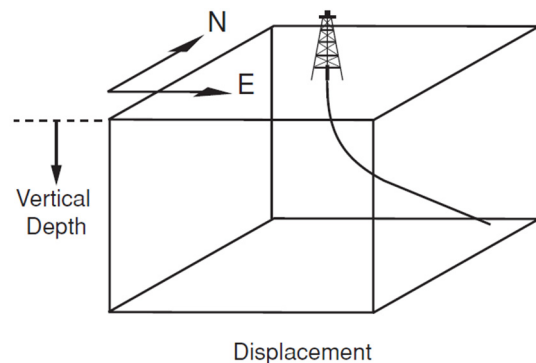

FIGURE 4: Well planning reference systems

- The vertical depth of the point below a particular reference point.
- The horizontal distance traversed from the wellhead in a northerly direction.
- The distance traversed from the wellhead in an easterly direction.

The depth of a particular point on the well path, referred to as true vertical depth (TVD) is expressed in metres (feet) vertically below a reference (datum) point. The northerly and easterly displacement of the point horizontally from the wellhead is reported as Northing/easting or longitude/latitude.

2.2.3 Defining the well path

Having fixed the target and the rig position, the next stage is to plan the geometrical profile of the well to reach the target. The most common well trajectory is the build and hold profile, which consists of 3 sections - vertical, build-up and tangent. The trajectory of the wellbore can be plotted when the following points have been defined:

- KOP kick-off point (selected by engineer);
- TVD and horizontal displacement of the end of the build-up section; and
- TVD and horizontal displacement of the target (defined by position of rig and target).

Since the driller will only be able to determine the long hole depth of the well, the following information will also be required:

- A long hole depth (AHD) of the KOP (same as TVD of KOP);
- Build up rate for the build-up section (selected by engineer);
- Direction in which the well is to be drilled after the KOP in degrees from north (defined by position of rig and target);
- AHD at end of build (EOB) and the tangent section commences; and
- AHD of the target.

These depths and distances can be defined by a simple geometrical analysis of the well trajectory.

2.3 Well path calculation

2.3.1 Build-and-hold

The following information is required:

- a) Surface (slots) coordinates;
- b) Target coordinates;
- c) True vertical depth of target;
- d) True vertical depth to KOP;
- e) Build-up-rate.

The choice of slot depends on a number of factors including target location and the proximity of other wells. The target coordinates and depth are selected by the geologist. The choice of KOP and build-up rate has to be made by the directional engineer (Bourgoyne, at al., 1991):

Figures 5 and 6 show a build-and-hold wellbore trajectory intersecting a target at a true vertical depth (TVD) of TVD_3 and at a horizontal departure of D_h (point D). The kickoff point is at a TVD of depth TVD_1 , where the rate of inclination angle build-up is q in degrees per unit length.

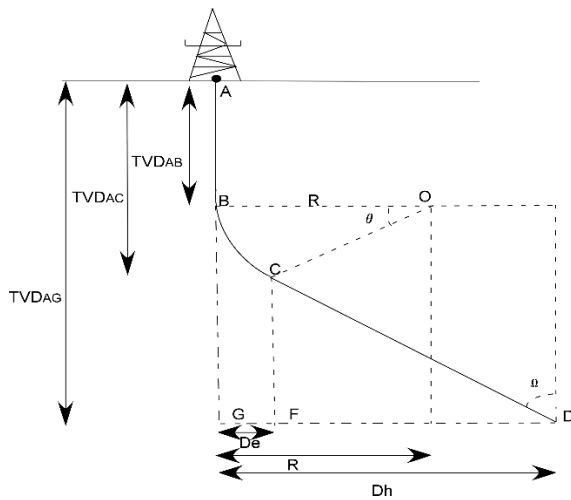

FIGURE 5: Geometry of build-and-hold type well path for $D_h > R$

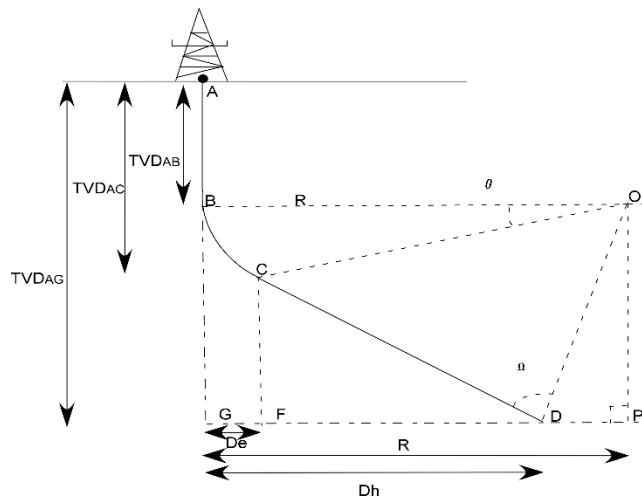

FIGURE 6: Geometry of build-and-hold type well path for $R > D_h$ (same definitions as for Figure 5)

- TVD_{AB} : Distance from the surface location to the KOP;
- $B-D$: Distance from KOP to the bottom of hole;
- D_h : Deviation of the wellbore from the vertical (Horizontal displacement);
- TVD_{AG} : True vertical depth;
- $MD (A-D)$: Well measured depth; and
- q : Build up rate ($^{\circ}/30$ m).

For the following formula, note that $TVD_3 = TVD_{AG}$, $TVD_2 = TVD_{AC}$, $TVD_1 = TVD_{AB}$. The radius of curvature, R , is thus:

$$R = \frac{180^{\circ}}{\pi} * \frac{1}{q} \tag{1}$$

where q is the build-up rate in $^{\circ}/30$ m.

To find the maximum inclination angle, θ , consider in Figure 6 that:

$$90^\circ = \theta + (90^\circ - \Omega) + \tau$$

or:

$$\theta = \Omega - \tau \quad (2)$$

The angle τ can be found by considering the triangle OPD, where (case $R > D_h$):

$$\tan \tau = \frac{DP}{PO} = \frac{R - D_h}{TVD3 - TVD2} \quad (3a)$$

and

$$\tau = \arctan\left(\frac{R - D_h}{TVD3 - TVD1}\right) \quad (3b)$$

Angle Ω can be found by considering ODC, where:

$$\sin \Omega = \frac{R}{OP} \quad (4)$$

and

$$Lob = \sqrt{(R - D_h)^2 + (TVD3 - TVD1)^2}$$

Substituting OP into Equation 4 gives:

$$\sin \Omega = \frac{R}{\sqrt{(R - D_h)^2 + (TVD3 - TVD1)^2}} \quad (5)$$

The maximum inclination angle, θ , for the build-and-hold case where $D_h < R$ is:

$$\theta = \arcsin\left[\frac{R}{\sqrt{(R - D_h)^2 + (TVD3 - TVD1)^2}}\right] - \arctan\left(\frac{R - D_h}{TVD3 - TVD1}\right) \quad (6)$$

The length of the arc, section BC, is:

$$L(BC) = \frac{\pi}{180^\circ} * R * \theta \quad (7)$$

or:

$$L(BC) = \frac{\theta}{q} \quad (8)$$

The length of the trajectory path, CD, at a constant inclination angle can be determined from triangle DCO as:

$$\tan \Omega = \frac{CO}{Lcb} = \frac{R}{Lcb} \quad (9)$$

and

$$Lcb = \frac{R}{\tan \Omega} \quad (10)$$

The total measured depth, D_M , for a true vertical depth of $TVD3$ is:

$$D_M = TVD1 + \frac{\theta}{q} + \frac{R}{\tan \Omega} \quad (11)$$

where D_M equals the vertical section to kickoff plus build section plus constant inclination section (Figures 6 and 7).

The horizontal departure GF (D_E) at the end of the build can be determined by considering D'CO, where:

$$D_E = R - R \cos \theta = R(1 - \cos \theta) \tag{12}$$

To find the measured depth and horizontal departure along any part of the build before reaching maximum angle θ , consider the intermediate inclination angle θ' , the inclination angle at C', which will yield a new horizontal departure, D_n .

The preceding derivation is valid only when $D_h < R$. Another way of expressing the maximum inclination angle, θ , in terms of R , $TVD1$, $TVD3$, and D_h for $D_h > R$ is:

$$\theta = \arctan\left(\frac{TVD3 - TVD1}{R - D_h}\right) - \arccos\left[\left(\frac{R}{TVD3 - TVD1}\right) * \sin\left(\arctan\left(\frac{TVD3 - TVD1}{R - D_h}\right)\right)\right] \tag{13}$$

2.3.2 Build-hold and drop

The second type of trajectory is the build, hold, and drop or S shape curve, which is depicted in Figure 7, for the cases where $R < D_h$ and $R+R1 > D_t$, and in another case where $R < D_h$ and $R+R1 < D_t$. In all of these cases, the maximum inclination is reduced to zero at D_t with drop radius $R1$, which is derived in the same manner as the build radius, R .

- TVD_{BG} : Distance from the surface location to the KOP;
- TVD_{AG} : True vertical depth of well (TVD);
- $B-D$: Distance from KOP to the bottom of hole (MD);
- $G-D$: Deviation of the wellbore from the vertical to the end of tangent section;
- $G-P$: Deviation of the wellbore from the vertical to the end of drop section;
- $A-G$: True vertical depth;
- $A-P$: Measured depth; and
- D : End of tangent section.

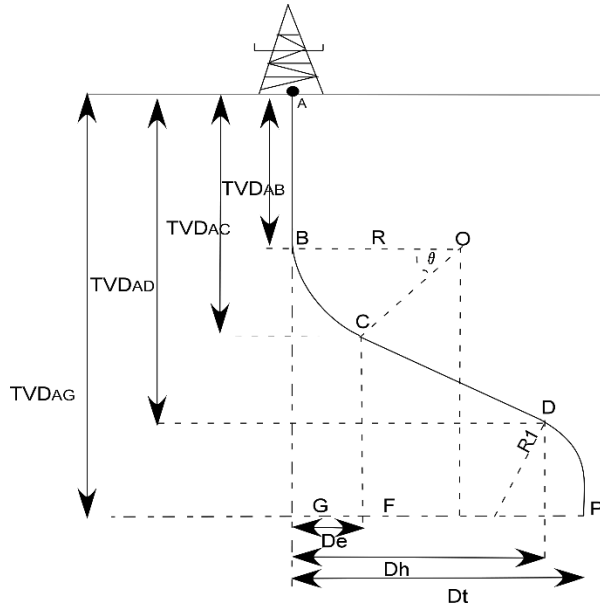

FIGURE 7: Geometry of build-hold and drop type well path for $R > D_h$ and $R+R1 < D_t$

The following equations are used to calculate the maximum inclination angles for $R+R1 > D_t$ and $R+R1 < D_t$:

$$\theta = \arctan\left(\frac{TVD4 - TVD1}{R + R1 - D_t}\right) - \arccos\left[\left(\frac{R + R1}{TVD4 - TVD1}\right) * \sin\left(\arctan\left(\frac{TVD3 - TVD1}{R + R1 - D_t}\right)\right)\right] \tag{14}$$

$$\theta = 180^\circ - \arctan\left(\frac{TVD4 - TVD1}{R + R1 - D_t}\right) - \arccos\left[\left(\frac{R + R1}{TVD4 - TVD1}\right) * \sin\left(\arctan\left(\frac{TVD3 - TVD1}{R + R1 - D_t}\right)\right)\right] \quad (15)$$

2.4 Directional drilling tools

There are a number of tools and techniques which can be used to change the drilling direction of the bit. These tools and techniques can be used to change the inclination or the azimuthal direction of the wellbore or both. All of these tools and techniques work on one of two basic principles. The first principle is to introduce a bit tilt angle into the axis of the BHA just above the bit; the second is to introduce a side force to the bit (Figure 8). The introduction of a tilt angle or side force to the bit will result in the bit drilling off at an angle from the current trajectory. This is currently the most used method in geothermal drilling.

The major tools currently used for this purpose are:

- *Steerable positive displacement motor*, currently used mostly in geothermal;
- *Non-rotating steerable drilling systems*;
- Rotary steering system;
- Directional *bottom hole assemblies (BHA)*; and
- *Whipstocks*, mostly used for sidetracks.

The most commonly used technique for changing the trajectory of a geothermal wellbore uses a piece of equipment known as a positive displacement (mud) motor. The end of the motor may be set at an angle to introduce tilt to the bit. The motor is powered by the drilling fluid being pumped down the drill string and it rotates the drill bit. The end of the motor may be set at a small angle to deflect the bit and thus gain trajectory deflection. By “sliding” (i.e. drilling without rotation) the motor turns the bit and the set angle allows deflection of the wellbore. In between the well is drilled by rotating the drillstring and thus a straight wellbore trajectory is obtained. By mixing these both methods the well trajectory may be deflected, without introducing too high a dogleg.

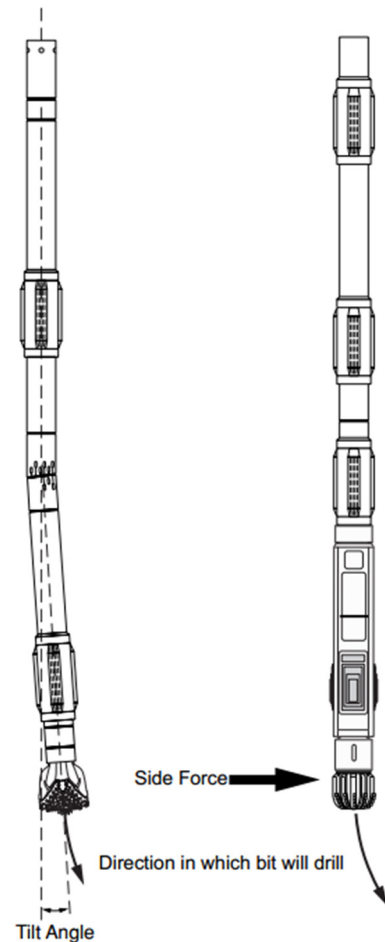

FIGURE 8: Bit tilt angle and side force (Baker Hughes INTEQ, 1995)

Sidetrack is when a new well path is to be obtained out of a previous one. The main sidetrack methods used in directional drilling are:

- Whipstocks, the retrievable, open-hole whipstock is only used in special applications, e.g. rigs with small pumps, and sidetracks in deep, very hot holes. The whip-stock is pinned to a limber BHA which includes a small bit. A typical BHA is:
 - Motors, in this method, a bent sub is run directly above a PDM. A typical BHA is as follows: Bit + PDM + bent sub + float sub + orienting sub (UBHO) + non-magnetic DCs + HWDP + DP.
 - Whip-stock + pilot bit + stabilizer + shearpin sub + 1 joint of drill pipe + UBHO + non-magnetic DC.
- Jetting, this technique is used to deviate the wellbore in soft and friable formations. The well can be kicked off and built up to maximum inclination using one BHA. A typical jetting BHA is:

- Bit + near-bit stab. + UBHO (universal bottom hole orientation) + MWD + NMDC (non-magnetic drill collar) + stab + DC + stab., etc.

2.5 Well surveying

During drilling it is close to impossible to make the actual trajectory precisely match the designed well path. For that reason, it is important to monitor the well trajectory and take corrective actions as the well is being drilled. To achieve this goal there must be reliable survey measurement tools and techniques that determine inclination, azimuth and perhaps the tool face orientation at different points along the well path. Survey tools only provide an incremental departure from a known starting point. The known point is referred to as the tie-on, or ties line. The first survey station is recorded deeper than the tie-on. The tools measure inclination and azimuth, the MD is known. The points of measurements are called survey stations. The measured parameters are then used to calculate the wellbore position in terms of the 3D coordinates N, E and TVD. Inclination angle is measured with respect to the vertical while azimuth is measured with respect to either magnetic or true north. But azimuth is typically reported in reference to true or grid north. As a result, the azimuth needs to be corrected before being reported or used in calculations. True north is the absolute north reference. Magnetic Declination is the angle from true north to magnetic north, and Grid Convergence is the angle from true north to grid north.

2.5.1 Application

When planning a 3D well trajectory, one of the most important considerations is torque and drag. If the torque and drag are not carefully considered, the drill string might fail. The torque and drag model used makes special assumptions that simplify the analysis and are used to model real drill strings. The most important factor influencing the torque and drag forces is the hole curvature. The well path should be redesigned with a smaller build-up rate if the drill string seems to fail when simulating these forces during the design stage. There are many causes for excessive torque and drag such as: sliding friction, tight hole, collapsing or swelling clay/shale, key seats, differential sticking and cuttings build-up. The minimum curvature method assumes the bending part in the equilibrium equation used to calculate torque and drag is discontinuous at survey stations. Some authors mean this is one of the main weaknesses of using the minimum curvature method. Due to the missing bending stresses, the method might not represent the real drill string configuration.

2.5.2 Survey calculation methods

There are several methods of computing directional surveys (Figure 9). However, only four are commonly used today. The main methods are:

- Average angle;
- Tangential;
- Balanced tangential (rarely used);
- Radius of curvature; and
- Minimum curvature.

The tangential method gives significant errors throughout the wellbore path, as well as the bottom hole location. The balanced tangential method is included as it is the basis for the minimum curvature method. These methods use inclination and azimuth at a specified measured depth. The difference between these methods is how they process the raw survey

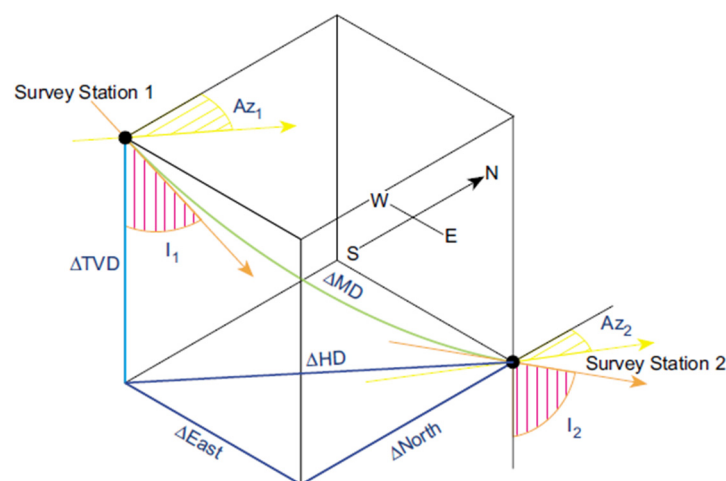

FIGURE 9: Survey

data of inclination, azimuth, and measured depth. The following paragraphs are a description of these methods (Sperry-Sun, 2001).

A. Average angle method

The average angle method (Figure 10) uses the average of the inclinations and azimuths measured at the upper and lower survey stations. The average of the two sets of angles is assumed to be the inclination and the azimuth over the incremental measured depth. The wellbore path is then calculated using simple trigonometric functions.

Average angle calculations:

$$\Delta_{NORTH} = \Delta MD * \sin \left(\frac{I1 + I2}{2} \right) * \cos \left(\frac{Az1 + Az2}{2} \right) \tag{16}$$

$$\Delta_{EAST} = \Delta MD * \sin \left(\frac{I1 + I2}{2} \right) * \sin \left(\frac{Az1 + Az2}{2} \right) \tag{17}$$

$$\Delta_{TVD} = \Delta MD * \cos \left(\frac{I1 + I2}{2} \right) \tag{18}$$

- where *MD* = Measured depth between surveys (m);
- I1* = Inclination (angle) at upper survey (°);
- I2* = Inclination (angle) at lower survey (°);
- Az1* = Azimuth direction at upper survey (°); and
- Az2* = Azimuth direction at lower survey (°).

B. Tangential method

The tangential method (Figure 11) uses the inclination and azimuth at the lower end of the course length to calculate a straight line that represents the well bore, and passes through the lower end of the course length. The wellbore is assumed to be a straight line throughout the course length. This method is the most inaccurate of the methods discussed and should not be used in the determination of survey results unless the course lengths are not longer than the length of the survey tool.

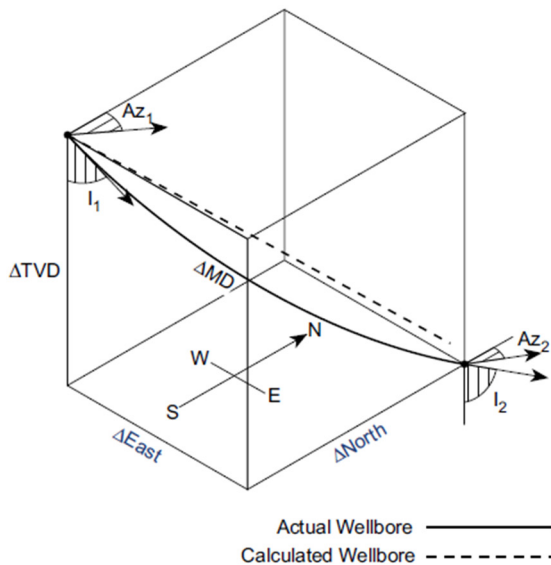

FIGURE 10: Average angle method

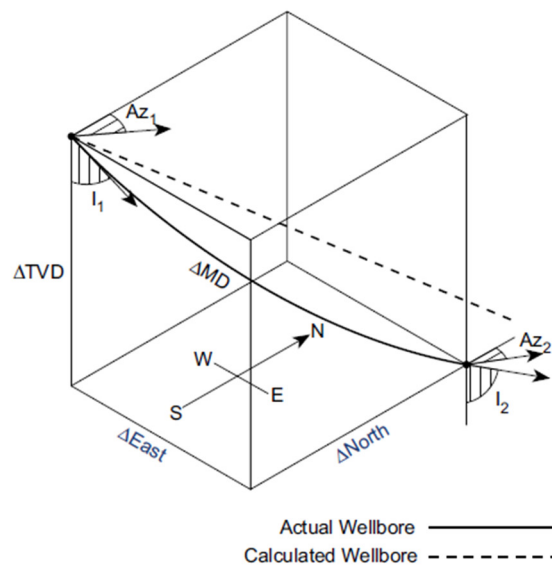

FIGURE 11: Tangential angle method

Tangential calculations:

$$\Delta_{NORTH} = \Delta MD * \sin I2 * \cos Az2 \tag{19}$$

$$\Delta_{EAST} = \Delta MD * \sin I2 * \sin Az2 \tag{20}$$

$$\Delta_{TVD} = \Delta MD * \cos I2 \tag{21}$$

where *MD* = Measured depth between surveys (m);
I2 = Inclination (angle) of lower survey (°); and
Az2 = Azimuth direction of lower survey (°).

C. Radius of curvature method

The radius of curvature method (Figure 12) uses the inclination and azimuth measured at the upper and lower ends of the course length to generate a circular arc when viewed in both the vertical and horizontal planes. This method assumes that the well path lies on a cylinder whose axis is vertical, and has a radius equal to the radius of curvature in the horizontal plane. It determines the length of the arc between the upper and lower ends of the course length in the horizontal plane. The cylinder can then be “unwrapped” to calculate the length of the circular arc along the cylinder surface. Consequently the incremental TVD is unaffected by changes in azimuth.

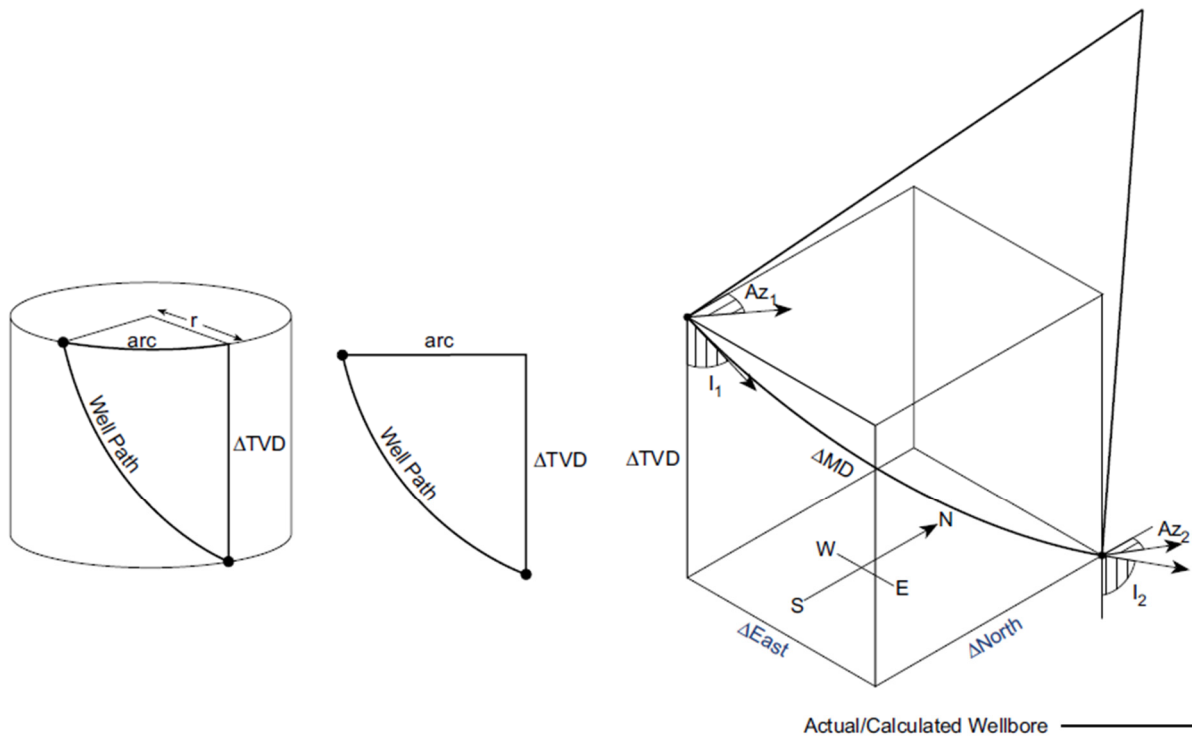

FIGURE 12: Radius of curvature method

Radius curvature calculations:

$$\Delta_{NORTH} = \frac{\Delta MD * [(\cos I1 * \cos I2) + (\sin Az2 * \sin Az1)]}{(I2 - I1) * (Az2 - Az1)} \tag{22}$$

$$\Delta_{EAST} = \frac{\Delta MD * [(\cos I1 * \cos I2) + (\cos Az1 * \cos Az2)]}{(I2 - I1) * (Az2 - Az1)} \tag{23}$$

$$\Delta_{TVD} = \frac{\Delta MD * (\sin I2 - \sin I1)}{(I2 - I1)} \tag{24}$$

where MD = Measured depth between surveys (m);
 $I1$ = Inclination (angle) at upper survey ($^{\circ}$);
 $I2$ = Inclination (angle) at lower survey in degrees ($^{\circ}$);
 $Az1$ = Azimuth direction at upper survey ($^{\circ}$); and
 $Az2$ = Azimuth direction at lower survey ($^{\circ}$).

D. Minimum curvature method

This model takes the space vectors defined by inclination and direction measurements and smooths them onto the wellbore curve (Figure 13). This method is really a modification of the balanced tangential method. Instead of approximating the wellbore path with two straight lines, the minimum curvature replaces these lines with a circular arc. This arc is calculated by using a dogleg scale factor based on the amount of angular change over the course length. The plane of the arc is at an oblique angle.

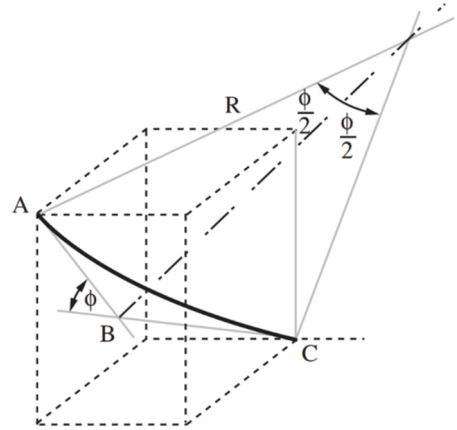

FIGURE 13: Minimum curvature method

Minimum curvature calculation:

$$\Delta_{NORTH} = \frac{\Delta MD}{2} * [(\sin I1 * \cos Az1) + (\sin I2 * \cos Az2)] * RF \tag{25}$$

$$\Delta_{EAST} = \frac{\Delta MD}{2} * [(\sin I1 * \sin Az1) + (\sin I2 * \sin Az2)] * RF \tag{26}$$

$$\Delta_{TVD} = \frac{\Delta MD}{2} * (\cos I1 + \cos I2) * RF \tag{27}$$

where

$$RF = \frac{2}{\theta} * \tan \frac{\theta}{2} \tag{28}$$

and

$$\cos \theta = \cos(I2 - I1) - \sin I1 * \sin I2 * (1 - \cos(Az2 - Az1)) \tag{29}$$

Also MD = Measured depth between surveys (m);
 $I1$ = Inclination (angle) of upper survey ($^{\circ}$);
 $I2$ = Inclination (angle) of lower survey ($^{\circ}$);
 $Az1$ = Azimuth direction of upper survey ($^{\circ}$);
 $Az2$ = Azimuth direction of lower survey ($^{\circ}$);
 RF = Ratio factor.

2.5.3 Surveying tools

When drilling a directional well, the actual trajectory of the well must be regularly checked to ensure that it is in agreement with the planned trajectory. This is done by surveying the position of the well at regular intervals. These surveys will be taken at very close intervals (~12 m, or every connection) in the critical sections (e.g. in the build-up section) of the well. While drilling the long tangential section of the well, surveys may only be required every 36 m (or every third connection). The surveying programme will generally be specified in the drilling programme. If it is found that the well is not being drilled along its planned course, a directional orientation tool must be run to bring the well back on course. In general, the earlier such problems are recognised the easier they are to correct. Surveying therefore plays a vital role in directional drilling.

A. Measurement while drilling (MWD) tools

The inputs for the above mentioned methods are MD, inclination and azimuth. MWD tools are a reliable and a fast way to measure these parameters and steer a well in the desired direction while keeping track of the wellbore trajectory. MWD tools use accelerometers which measure local acceleration and magnetometers that measure the earth's magnetic field. When drilling with the OnTrak MWD system, surveys are taken after every stand (approximately every 10-30 m). The pumps are shut down and, when a new connection is made up and pumps are turned back on, the tool's directional sensors measure Inclination and Azimuth. The OnTrak (inclination measurements) system needs to be stationary and non-rotating to take an accurate survey. The AutoTrak, which has a directional sensor that measures inclination continuously, is capable of accurately measuring inclination while being rotated. This makes it an ideal tool to use when for instance Geosteering. The inclination measured can then be compared to the OnTrak inclination measurements to get a more accurate wellbore position. Many companies, such as Baker Hughes, offer different types of MWD tools. One of the most used MWD tools is the Baker Hughes AutoTrak G3 rotary steerable system which consists of an AutoTrak steering unit with an OnTrak system for real-time MWD/LWD measurements.

B. Gyro measurement while drilling

Gyro measurement while drilling was introduced as an alternative to the gyro single shot tool for some applications. While the gyro single shot is run on the wire line, the gyro MWD is a real-time tool run alone or with a regular MWD tool on the drill pipe. Gyro MWD is commonly used in the top sections to get a more accurate magnetic interference measurement. This will, in turn, reduce the risk of colliding with an existing wellbore when drilling from a platform. The gyro-MWD technology is also used for orienting and setting whipstocks for side-tracking wells where regular MWD tools may be affected by magnetic interference.

3. CASE STUDY IN THE ASAL RIFT

Six wells have been drilled in the Asal Rift (1986-1987), recorded by Italian consultants (Aquater, 1989). These wells are vertical. Wells A1 and A2 were drilled in 1975. A1 produced geothermal fluid at 250°C with salinity of 130 g/l from a depth of 1070 m. A2 was not productive. Wells A3 to A6 were drilled from June 1987 to June 1988. Of these wells, wells A3 and A6 encountered a productive aquifer at 1100-1300 m depth. A new prefeasibility study was carried out in 2007 in the Asal Rift by Icelandic consultants from Iceland GeoSurvey and Reykjavik Energy Invest (REI) (Figures 14 and 15). The geological (Khodayar, 2008) and geophysical (Árnason et al., 2008) results

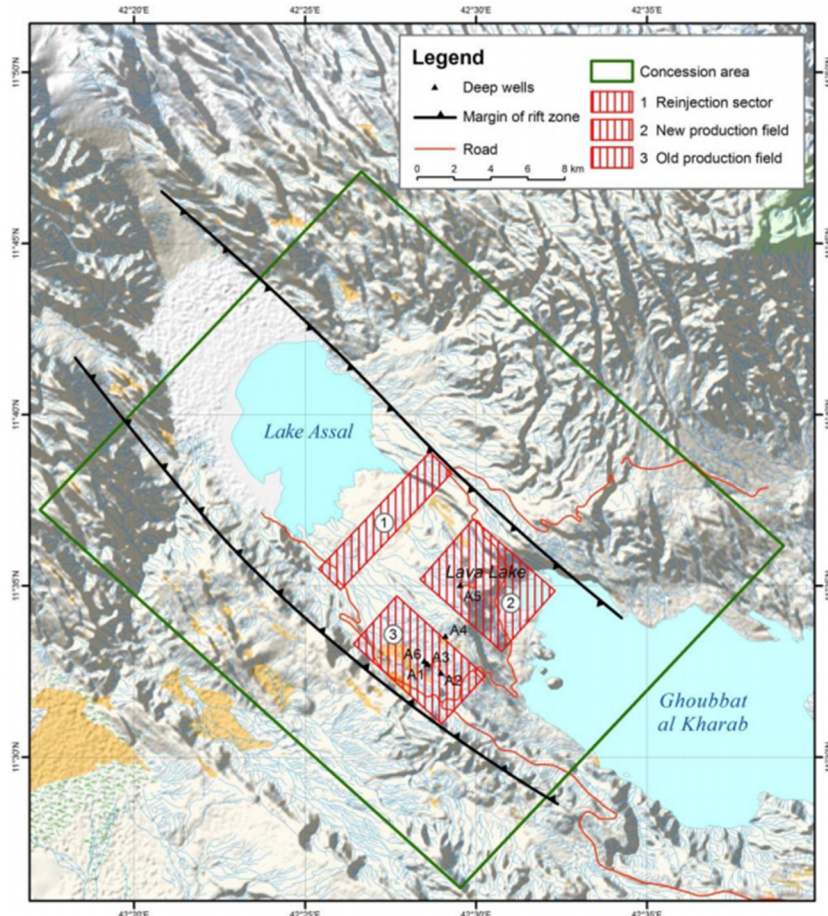

FIGURE 14: Asal Field, concession area for drilling (REI, 2009)

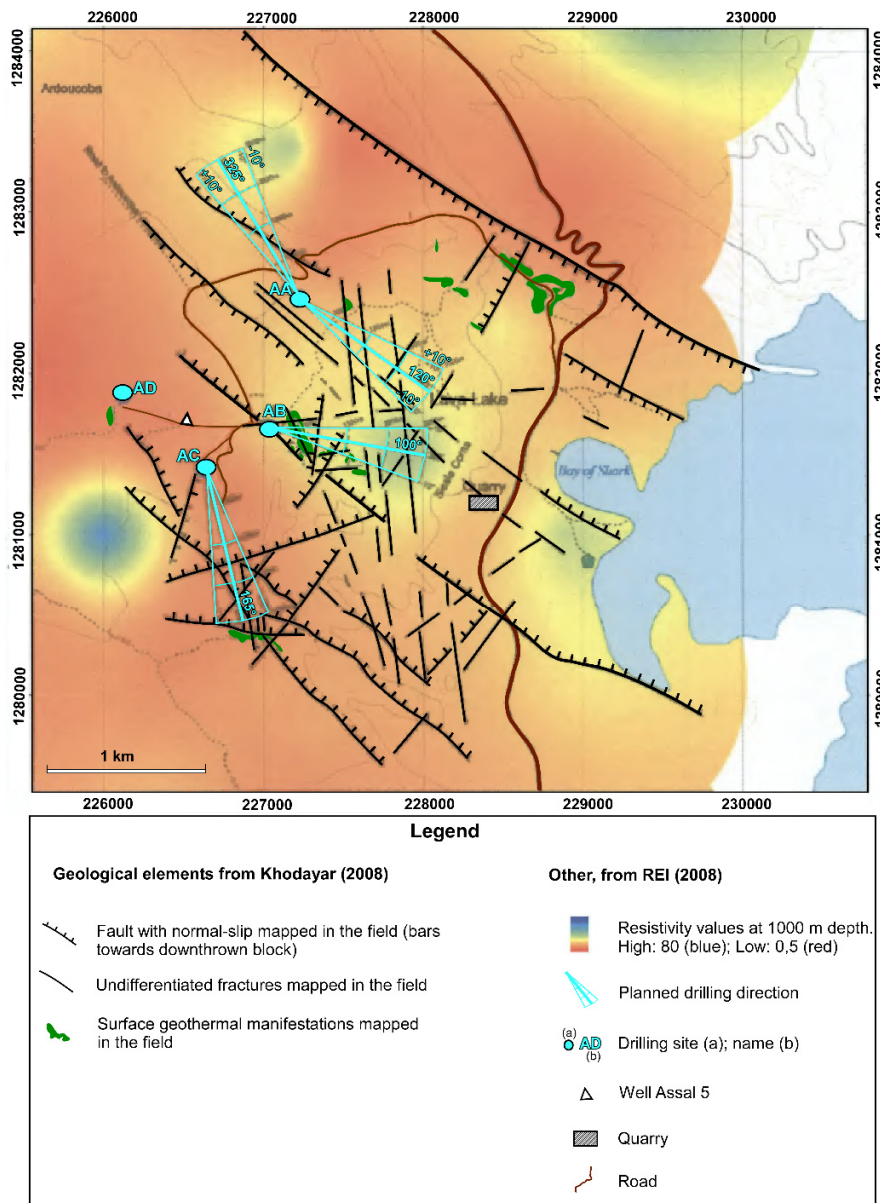

FIGURE 15: Well path of four targets inside and outside of the Lava Lake (Fialé) for directional drilling, as suggested by REI (2009)

of the pre-feasibility phase identified Fialé in the Asal Rift as a favourable production sector due to its impressive faulting, massive magma deposition and active steam fumaroles on the surface (Figure 14); the production section of well A5 of the former Asal drilling project is located within the sector. Well A5 was unproductive and penetrated both cold and hot formations. This resource behaviour suggests firstly that there are active flow channels of fresh seawater that recharge a deep reservoir. These faults should provide pressure support and more favourable fluid chemistry than observed in the old well (field sector A). The high downhole temperature confirms a large heat reserve. Based on these results, four new wells (AA to AD) from four drill pads were suggested by REI (REI, 2009), aiming at targets within and in the immediate surroundings of Fialé (Figure 15).

3.1 Objective

The geothermal wells planned by REI are to be drilled down to 2500 m depth and they are all to be directional. In order to reach the drilling targets, the drill sites were chosen to be located where discharge brine could be disposed of and where disturbances to the pristine environment would be at a minimum.

If the geothermal resource proves accessible, it is expected that more wells, perhaps as many as 5, will be drilled from the same drill pads. In this way, the roadwork and surface piping could be kept to a minimum. A storage place will be set up at the drill site, most likely between sites AC and AD. This is a flat area where drilling material and equipment are stored after having been shipped to Djibouti and transported to the Fialé drilling area. Part of the storage area will be fenced and a part of it will be roofed for protection against the sun. The four wells (AA to AD) are planned to be drilled vertically using percussion and rotary drilling assemblies, as applicable, to a kick off point (KOP) at approximately 350

m depth (Rotary Kelly Bushing). Inclination is to be built at a uniform rate of 3°/30 m to an inclination of 30°, with a specified nominal azimuth, which shall be maintained to the final well depth. The kick-off and initial build will be achieved with a mud motor and MWD equipment until the desired inclination and direction have been achieved. Once inclination and direction have been achieved, rotary assembly and electronic multi-shot measurement tools will be utilised. However, vertical drilling should be considered as an option, and its technical and cost aspects are briefly discussed in Section 3.5.

3.2 Geological context of the planned wells

The four planned wells are within the Asal Rift segment, which is one of the five rift segments in Djibouti. The other four are Alol, Gaggade, Hanle, and Goba'ad, all with geothermal potential. The five rift segments have a NNW to WNW strike. They are narrow elongated depressions, surrounded by elevated plateau and massifs. Their altitudes vary from 0 to 300 m a.s.l., except for the Asal segment which, at its northwest tip, drops to -150 m b.s.l. in the Asal Lake. These segments are among the major tectonic elements of the Afar depression. They have a complex geology since the Miocene period (Varet, 1978; Gaulier and Huchon, 1991) that includes: (a) successive volcano tectonic events related to the opening of the Red Sea, East African Rifts and Aden Ridge; (b) the shift of a rift from the Red Sea to the Afar Depression; (c) westward propagation of the Aden-Tadjourah ridges; (d) rift jumps and simultaneous activity of several rift segments; (e) the rotation of the Danakil Horst; and (f) complex kinematics and relative plate motion. Successive rifting since Miocene resulted in the accumulation of a vast basaltic trap and rhyolites in Afar, deposition of thick intercalated marine sediments as well as thinner lacustrine sediments filling the five rift segments. Magmatic and tectonic processes of the plate boundaries are the origin of geothermal activity in this part of Africa.

The Asal Rift itself (Figure 14) extends from the Gulf of Goubet in the southeast to Lake Asal in the northwest, bounded by major WNW striking normal faults. Due to its accessibility, this segment has been studied quite extensively, demonstrating that the rift is bounded by WNW striking major normal faults. The most active part of the Asal segment is the Inner Rift, which is about 3 km wide and is located to the southeast. The Inner Rift hosts most of the recent volcanism, with the last eruption dating from 1978. The most prominent feature of the Inner Rift is the Lava Lake, also called Fialé. The Lava Lake is an apparent crater about 1.3 km wide whose floor is covered by recent basaltic lavas.

The high geothermal potential of the Asal Rift is known from high-temperature exploration wells drilled over the past decades. While previous studies demonstrated the importance of the WNW normal faults of the rift, the recent geological pre-feasibility study shows two additional pieces of information on which grounds Fialé has been chosen as the target site (Khodayar, 2008): (a) there are more sets of fractures than the WNW set present within the rift; (b) Fialé could be a caldera, hosting the most significant surface geothermal manifestations of the Asal Rift segment.

3.2.1 Asal 5: An example of a well profile

Well Asal-5 (Figure 16) is the deepest well (2105 m) drilled in the Asal Rift and is unproductive as it penetrates both cold and hot formations. Data from this well (Árnason and Flóvenz, 1995) indicate a possible shallow hot reservoir (160°C) at 500-550 m depth, then a cold zone (about 60°C) down to 1200 m depth. Below 1200 m, temperature increases and the bottom temperature is about 333°C at 2105 m. The well has never been discharged. This temperature profile suggests firstly that there are active flow channels of fresh seawater recharging a deep reservoir. Secondly, the downhole high temperature confirms a large heat reserve. After the well became unsuccessful, Icelandic scientists familiar with the strategic research of similar geothermal fields joined the exploration of Asal Geothermal Field. The geological investigations of the Asal Field (Saemundsson, 1988) indicated that Well Asal-5 was not correctly sited as it would be about 700-1000 m from the geothermal up flow zone. Shortly thereafter, resistivity studies were undertaken using the TEM method (Transient Electromagnetics) in the Inner Rift (Árnason et al., 1988). The survey indicated the existence of an up flow zone of geothermal fluid

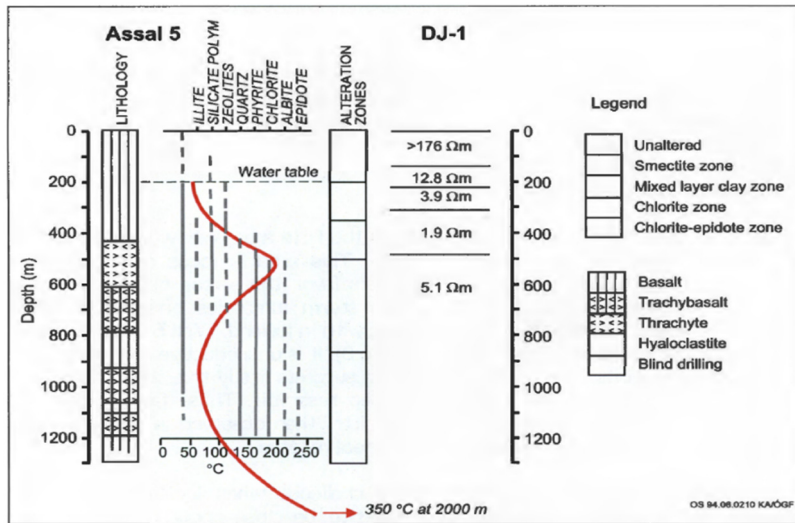

FIGURE 16: Temperature profile, geology, thermal alteration and TEM based resistivity model for well 5 (modified from Árnason and Flóvenz, 1995)

under the Lava Lake, as had been mentioned by Saemundsson (1988). These results showed this area to be the most promising for future exploratory wells.

3.2.2 Geophysical and geological results

The recommendations of REI for drilling in the Asal Rift (Figure 15) are based on the results of geophysical and geological pre-feasibility studies (Figures 17 and 18). Geophysical investigations within the rift segment show different high and low resistivity zones from 0 to 9000 m b.s.l. (Árnason et al.,

2008). Resistivity, in general, is indicative of past or present secondary (altered) minerals rather than the hydrology or the real subsurface temperatures. In particular, the map at 3000 m b.s.l. (Figure 17) delineates several low resistivity bodies, three of which (zones A, B and C) are the suggested potential geothermal sites. Area A is Fialé, whereas areas B and C are by the western flank of the rift segment. By analogy with Icelandic fields, the resistivity studies also infer the salinity of these areas so that there could be more open low salinity systems under the Lava Lake (Fialé), while areas B and C might be highly saline (Figure 17).

It is interesting to note that the salinity of wells A1 to A6 (115-130 g/l) is high (between 1000 and 1300 m), that of Ghoubet is very low (39.3 g/l at 25 m depth), while the Asal Lake to the northwest has the highest salinity (276.5 g/l at the surface and is

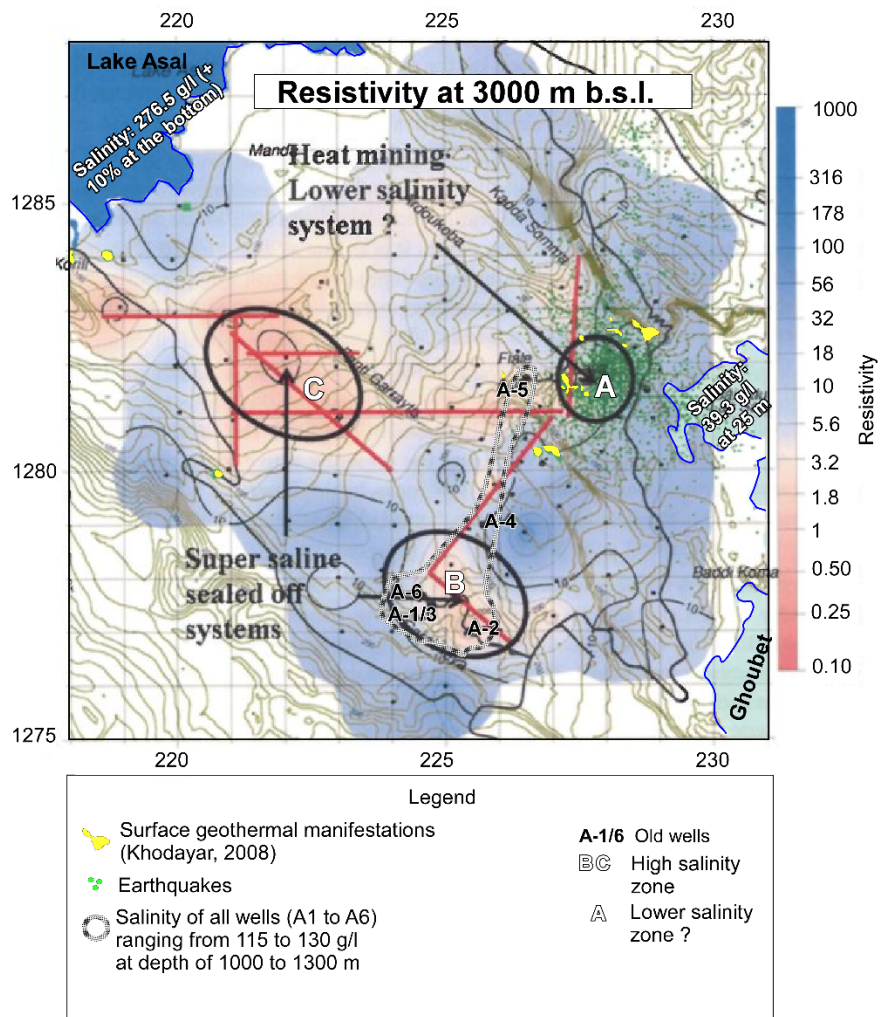

FIGURE 17: Resistivity 3000 m below sea level (modified from Árnason et al., 2008)

10% higher at the bottom) (Virkir-Orkint, 1990). This raises the question of the provenance of the saline water and the subsurface hydrology through rocks and/or open fractures.

The pre-feasibility geological field studies focused on Fialé, but a short investigation was also made in Korili/Gale le Kôma to the southwest of the Asal Lake (Khodayar, 2008). Results suggested both areas as having high potential. The detailed mapping of geology, tectonic and surface geothermal manifestations in Fialé identified three sub-areas (A, B, and C in Figure 18).

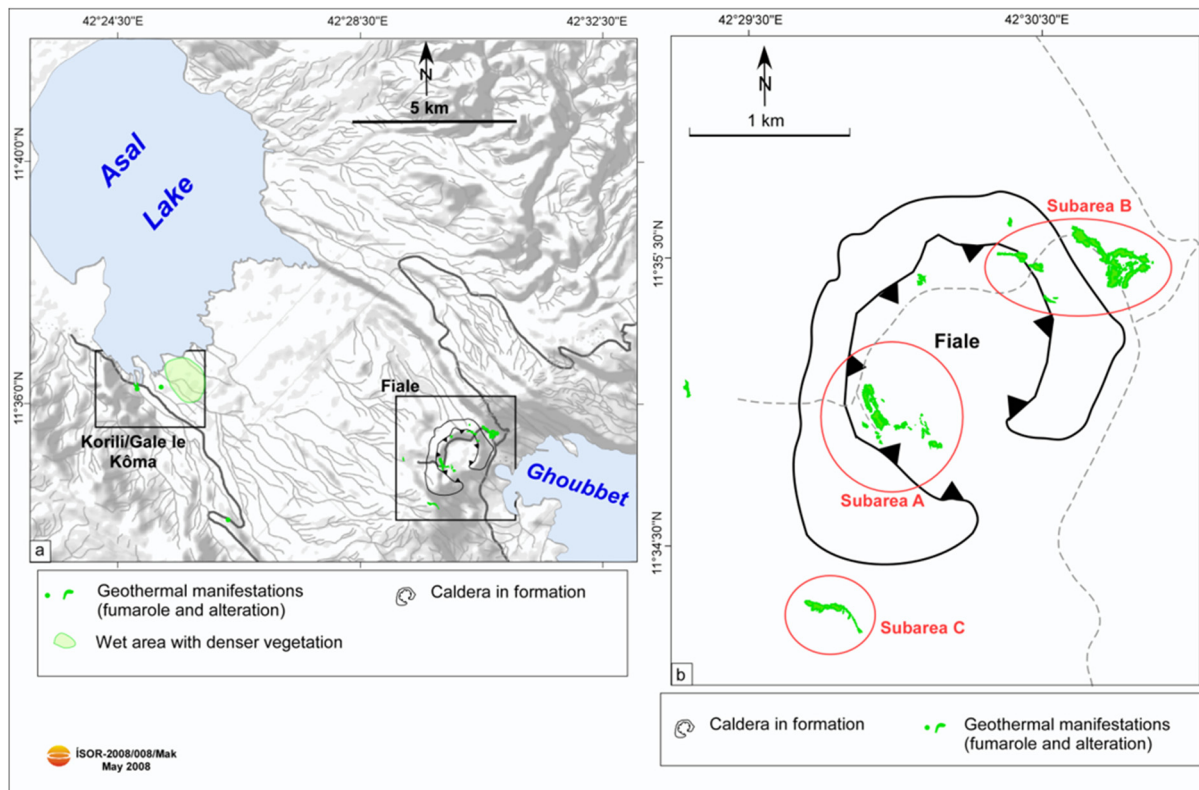

FIGURE 18: Location map of geothermal areas studied in the field (Khodayar, 2008)

The sub-area A to the west of Fialé has the highest potential as it has the most evidence of geothermal activity. The first target zone there is an altered zone with fumaroles and hot wet soil up to 91°C along an open NNW fracture. This fracture is seismically active and is monitored instrumentally. The second target zone is adjacent to the NNW fracture on the inner slope of Fialé where the hot wet soil reaches 75.5°C. In sub-area B to the east of Fialé (Figure 18), most alterations are aligned in WNW and ENE zones that coincide with the underlying WNW and ENE fractures. The WNW and ENE altered zones are respectively parallel to the adjacent inner rift boundary fault and to the trace of a major fault stretching from west-southwest of Fialé towards sub-area B. Sub-area C is high up on a rifted block above the outer slope of Fialé to the west. Along with the WNW faults of the rift, sets of fractures striking NNW, ENE and E-W were also mapped in and around the Lava Lake (Khodayar, 2008). Evidence of these fractures is also seen in geophysical results, and constitutes some of the targets chosen by REI for directional drilling (Figure 15). Finally, geological investigations suggested that Fialé might be a caldera (Khodayar, 2008), which is likely since seismicity is highest under the Lava Lake (Figure 18) and could be indicative of a magmatic body at depth.

3.2.3 Exploration wells

The proposed location of the four drill pads (shown in Figure 15) in Asal Fialé by REI (REI, 2008), are the following:

- a) Well AA is located on the outer slopes of the Lava Lake rim. The drilling target from drilling site AA is the inner part of the Lava Lake, especially the intersections of various fault lines identified by geological mapping. The horizontal distance from a drill pad is about 1000 m, making the drilling targets within the Lava Lake reachable from Site AA. Facing the site to the northwest, at the foot of the slope, is a flat area which could in the future be the location of a separation station and/or power house.
- b) The location of drill pad AB is on a flat plane bordered by low ridges with NW-SE directions. To the southeast the plane connects to the Lava Lake through a depression in the crater rim. The current track to the Ardoukoba crater ascends here from Lava Lake and traverses the drill site. From Site AB the main fumarole area could be reached by directional drilling towards the east, and by a southerly direction the main fault plane of the Fialé area could be penetrated.
- c) Parallel to the plane of Site AB, but to the southwest, is another flat area, bordered by a low ridge to the northeast and the high cliff of the main plane to the southwest. This plane is hidden from view and is large enough to accommodate drill pads, a separation station and a power house. Wells drilled from a pad in the southeast corner of the plain could reach drilling targets under Lava Lake and the important fault planes of the Fialé area.
- d) The location is farthest to the east, and is reserved as an option for the last exploration well if the drilling of the first well shows that the Lava Lake target is less promising than the area between the Lava Lake and the eastern fault boundary of the Inner Rift. This area could accommodate a few wells aimed at the faults of the eastern border of the Inner Rift. This drill pad would only be prepared if the other drill sites were found to be less suitable than currently anticipated.

3.2.4 Surface locations and targets

Four drill pads have been planned by REI, based on recommendations from the recent geological and geophysical studies from ISOR (Iceland GeoSurvey). The surface and target coordinates are shown in Tables 1 and 2.

TABLE 1: Surface coordinates of the proposed wells

Well	X (Easting) m	Y (Northing) m	Latitude/Longitude (Degrees/Minutes/ Seconds)	Latitude/Longitude (Degrees/ Decimal)	Elevation (m)
AA	227212.1	1282455	11°35'25.31"N 42°29'54.85"E	11.590364 N 42.498569 E	104
AB	227030.3	1281667	11°34'59.63"N 42°29'49.08"E	11.583235 N 42.496967 E	124
AC	226651.5	1281424	11°34'51.64"N 42°29'36.65"E	11.581009 N 42.493515 E	109
AD	226121.2	1281879	11°35'6.27"N 42°29'19.13"E	11.585078 N 42.488619 E	118

3.3 Planning the well path

TABLE 2: Target coordinates

The normal method for determining a well path is to ascertain coordinates by using some type of surveying instrument to measure the inclination and the direction at various depths (stations) and then calculate the trajectory. Appendix I shows the expected lithology and the scheduled design for Wells AA and AB.

	Target zone coordinates
Well AA	N120° or N325° (two propositions) N100° N165°
Well AB	
Well AC	

3.3.1 Trajectory calculations

In Asal, the plan is to drill under the Lava Lake to the locations designated as the four targets. For these wells, a build-and-hold trajectory will be used. Horizontal departure to the target zone is 1015 m at a TVD of 2247.2 m. The recommended rate of build is 3°/30 m. The kick-off depth is 350 m. We have to determine (1) the radius of curvature, R ; (2) the maximum inclination angle, θ ; (3) the measured depth to the end of the build; (4) the total depth measured; (5) the horizontal departure to the end of the build. The surface and target coordinates are shown in Section 3.2.4. Please note that these trajectory calculation results are the same for all four wells; only survey calculations using the target zone are different.

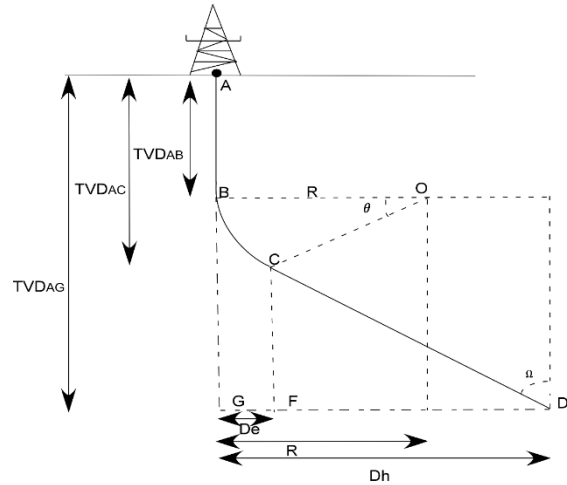

FIGURE 19: Geometry of build-and-hold type well path for $D_h > R$

Figure 19 shows the necessary parameters for the calculations. First the radius of the curvature is calculated. Note, $D_h > R$.

$$R = \frac{180}{\pi} * \frac{1}{\frac{3^\circ}{30 \text{ m}}} = 573 \text{ m}$$

For this case, $D_h > R$. A way of expressing the maximum inclination angle, θ , in terms of R , $TVD1$, $TVD3$, and D_h for $D_h > R$ is:

$$\theta = 180^\circ - \arctan\left(\frac{TVD3 - TVD1}{D_h - R}\right) - \arccos\left[\frac{R}{TVD3 - TVD1} * \sin\left(\arctan\left(\frac{TVD3 - TVD1}{D_h - R}\right)\right)\right] \quad (30)$$

$$\theta = 180^\circ - \arctan\left(\frac{2247 - 350}{1015 - 573}\right) - \arccos\left[\frac{573}{2247 - 350} * \sin\left(\arctan\left(\frac{2247 - 350}{1015 - 573}\right)\right)\right] = 30.21^\circ$$

The length of the arc, section BC, is calculated using Equation 7:

$$L(BC) = \frac{\pi}{180} * 573 * 30.21 = 302.12 \text{ m}$$

The measured depth to the end of build at an inclination of 30.21° is:

$$L(C) = TVD1 + \frac{\pi * R * \theta}{180} \quad (31)$$

$$L(C) = 350 + \frac{\pi * 573 * 30.12^\circ}{180^\circ} = 651.22 \text{ m}$$

The horizontal departure to the end of the build is calculated using Equation 12:

$$D_E = 573 * (1 - \cos 30.22^\circ) = 77.36 \text{ m} \approx 78 \text{ m}$$

The total measured depth to the target is:

$$L(d) = TVD1 + \frac{\pi * \theta * R}{180^\circ} + \frac{TVD3 - TVD1 - R * \sin \theta}{\cos \theta} \tag{32}$$

$$L(d) = 350 + \frac{\pi * 30.12^\circ * 573}{180^\circ} + \frac{2247 - 350 - 573 * \sin 30.12^\circ}{\cos 30.12^\circ} = 2512 \text{ m}$$

The total measured displacement depth to the target (maximum) is:

$$D_h = L(d) - TVD1 * \sin \theta \tag{33}$$

$$D_h = 2512 - 350 * \sin(30.12^\circ) = 1085 \text{ m}$$

A trajectory worksheet is shown in Figure 20.

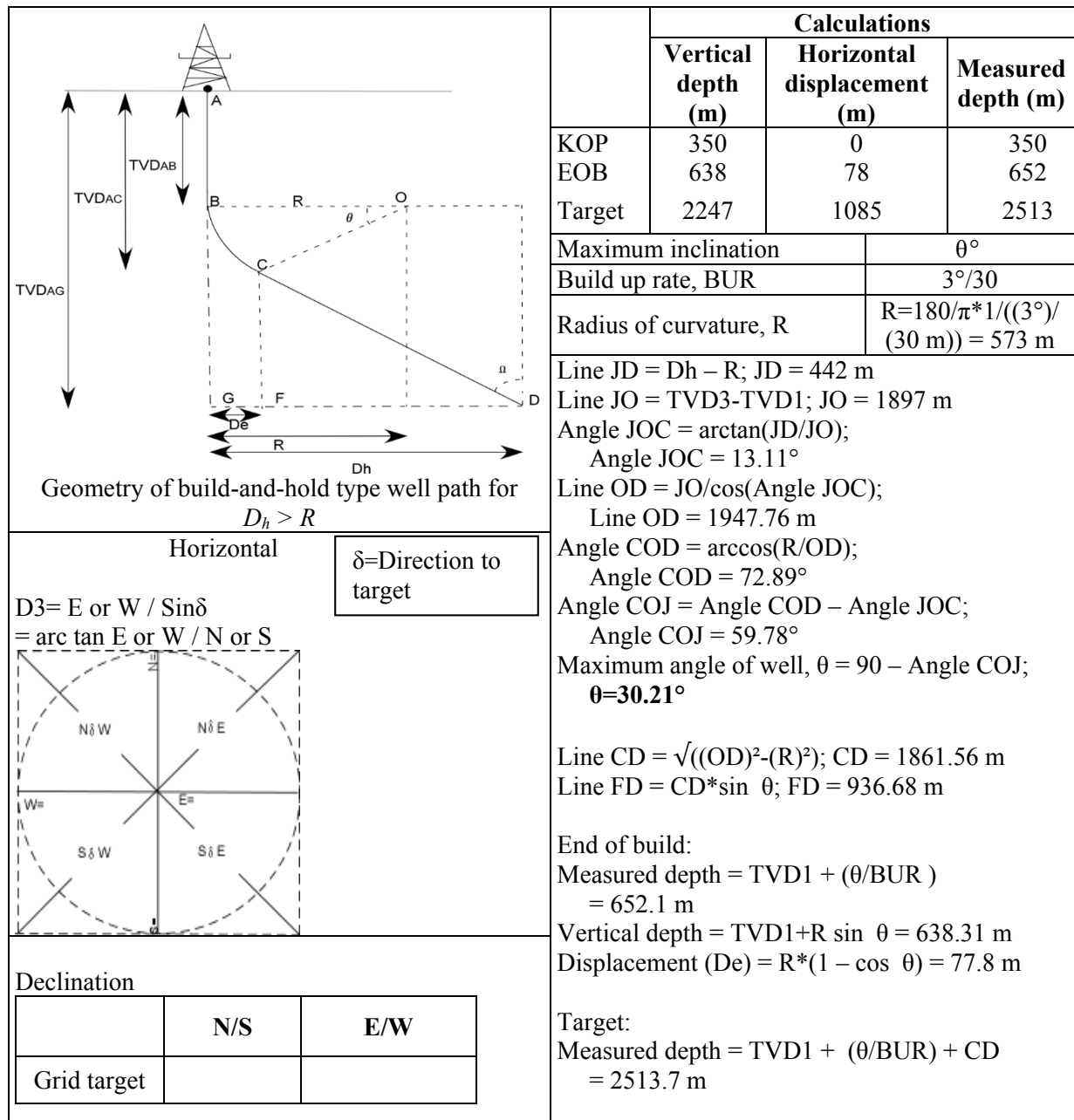

FIGURE 20: Trajectory worksheet

3.3.2 Directional survey calculations

The normal method for determining the well path is to ascertain the coordinates by using some survey method to calculate the inclination and direction at various depths (stations) and then calculate the trajectory. There are 18 or more calculation techniques for determining the trajectory of the wellbore. The main difference in all these techniques is that one group uses straight line approximations and the other assumes the wellbore is more of a curve and is approximated with curved segments. For this case, the minimum curvature method will be used (Figure 21) which is the most accurate and commonly used. Whilst drilling a deviated well, the measured depth, inclination and azimuth of the well are measured at station 2 (see survey data below). The north and east co-ordinates, TVD, vertical section and dogleg severity, of the next station are calculated according to the minimum curvature method.

This method smooths the two straight-line segments of the balanced tangential method using the *ratio factor*, RF. The survey information of measured depth, inclination, and azimuth are entered in the appropriate columns (i.e. measured depth-total, inclination, and azimuth-observed) in Table 3.

For Well AA:

At first, the dogleg angle, calculated from Equation 29:

$$\cos \theta = \cos(27^\circ - 3^\circ) - \sin 3^\circ * \sin 27^\circ * (1 - \cos(325^\circ - 325^\circ)) = 0.9135$$

$$\theta = \arccos 0.9135 = 24.00^\circ = 0.4188 \text{ radians}$$

Then, the ratio factor is obtained from Equation 28 ($\theta = B$ and must be radians):

$$RF = \frac{2}{0.4188} * \tan\left(\frac{24.0^\circ}{2}\right) = 1.0631$$

The East is calculated using Equation 26:

$$\Delta_{EAST} = \frac{620 - 380}{2} * ((\sin 3^\circ * \sin 325^\circ) + (\sin 27^\circ * \sin 325^\circ)) * 1.0631 = -35.81 \text{ m}$$

The North is calculated from Equation 25:

$$\begin{aligned} \Delta_{NORTH} &= \frac{620 - 380}{2} * ((\sin 3^\circ * \cos 325^\circ) + (\sin 27^\circ * \cos 325^\circ)) * 1.0631 \\ &= 51.15 \text{ m} \end{aligned}$$

The vertical (TVD) is obtained using Equation 27:

$$\Delta_{TVD} = \frac{620 - 380}{2} * (\cos 3^\circ + \cos 27^\circ) * 1.0631 = 233.5 \text{ m}$$

For Well AB:

The parameters of Well AB are shown in Table 4.

At first, the dogleg angle:

$$\cos \theta = \cos(27^\circ - 3^\circ) - \sin 3^\circ * \sin 27^\circ * (1 - \cos(100^\circ - 100^\circ)) = 0.9135$$

$$\theta = \arccos 0.9135 = 24.00^\circ = 0.4188 \text{ radians}$$

Then, the ratio factor:

$$RF = \frac{2}{0.4188} * \tan\left(\frac{24.0^\circ}{2}\right) = 1.0631$$

The East:

$$\Delta_{EAST} = \frac{620 - 380}{2} * ((\sin 3^\circ * \sin 100^\circ) + (\sin 27^\circ * \sin 100^\circ)) * 1.0631 = 61.49 \text{ m}$$

The North:

$$\Delta_{NORTH} = \frac{620 - 380}{2} * ((\sin 3^\circ * \cos 100^\circ) + (\sin 27^\circ * \cos 100^\circ)) * 1.0631 = -10.84 \text{ m}$$

The vertical (TVD):

$$\Delta_{TVD} = \frac{620 - 380}{2} * (\cos 3^\circ + \cos 27^\circ) * 1.0631 = 233.5 \text{ m}$$

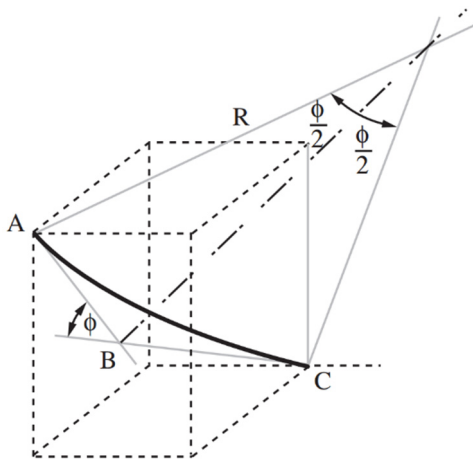

FIGURE 21: Minimum curvature method

TABLE 3: Parameters of Well AA

Station	MD	INC	AZI	TVD
02	380	3	325	379.83
09	620	27	325	609.96

TABLE 4: Parameters of Well AB

Station	MD	INC	AZI	TVD
02	380	3	100	379.83
09	620	27	100	609.96

3.3.3 Well path

Other calculation methods sometimes used are the balanced tangential method, the radius of curvature method, and the average angle method. The three-dimensional geometrical representation of the trajectory for Well AA is presented below, where the wellbore is deflected at point B. The well was turned clockwise for the N325° and N100° target zone, presented in Table 5:

TABLE 5: Target coordinates

	Target zone coordinates
Well AA	N120° or N325° (two propositions)
Well AB	N100°
Well AC	N165°

The different views of Well AA are presented in Figures 22 and 23.

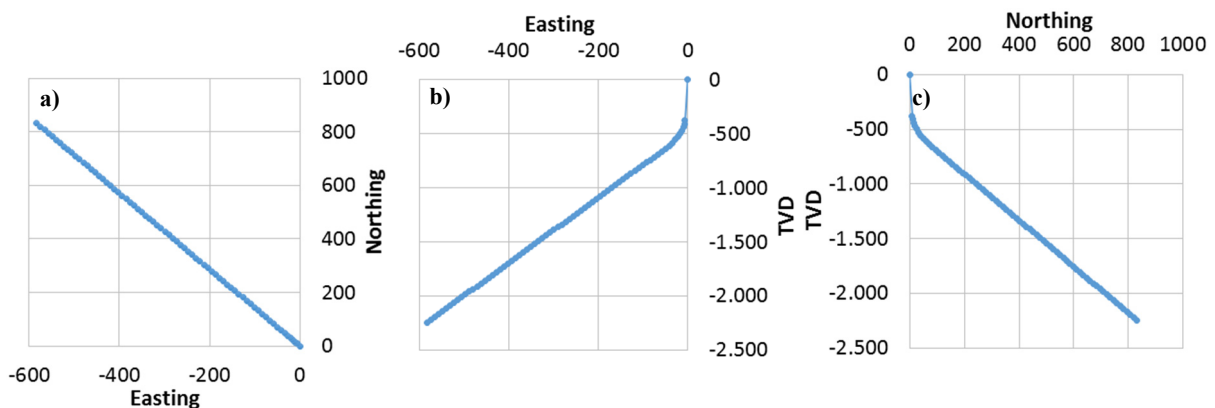

FIGURE 22: a): Horizontal displacement (D_h); b) A view from the south on the TVD projected on a vertical W-E plane; and c) A view from the east on the TVD projected on a vertical S-N plane

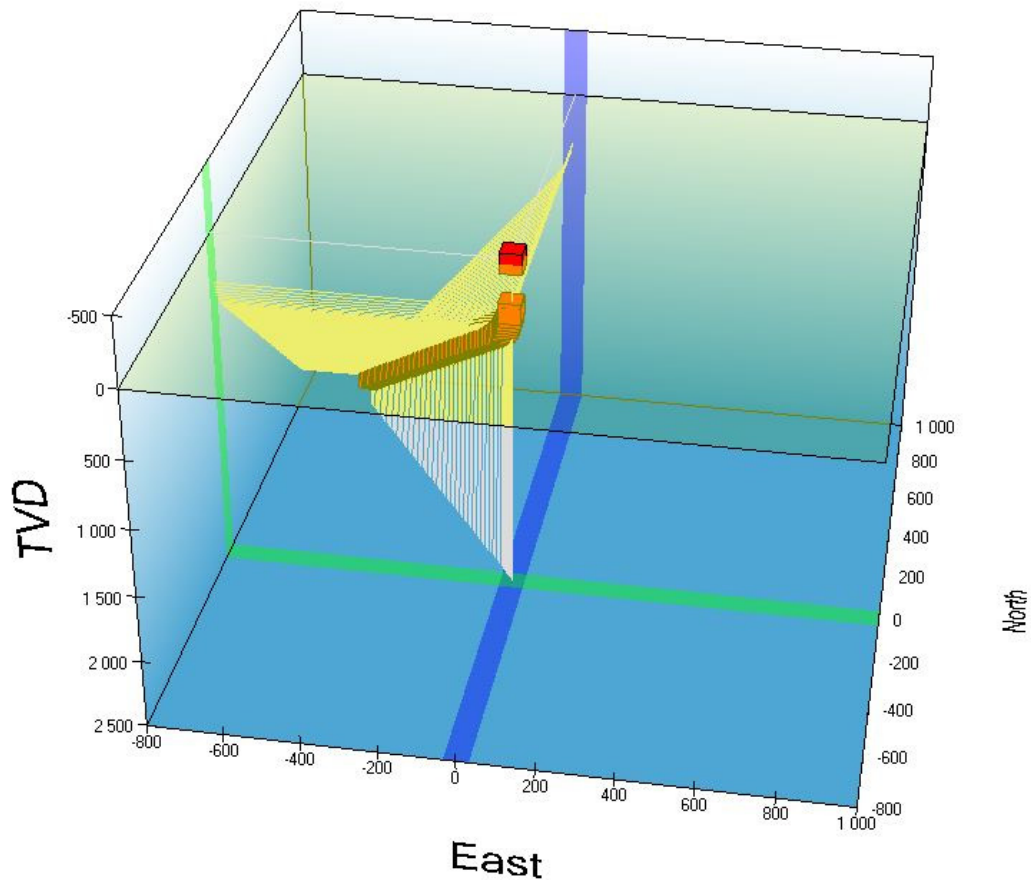

FIGURE 23: A 3D view trajectory of Well AA

The different views of Well AB are presented in Figures 24 and 25.

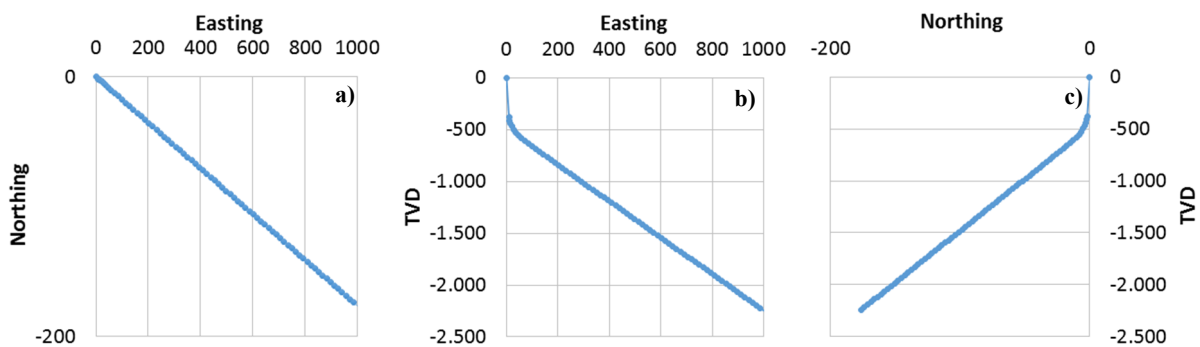

FIGURE 24: a) Horizontal displacement; b) A view from the south on the TVD projected on a vertical W-E plane; and c) A view from the east on the TVD projected on a vertical S-N plane

As to which method yields the most accurate results, Table 6 compares the four different calculation methods using data taken from a planned well. An example for comparison is Well AA.

Note that the tangential method shows considerable difference. This is why the tangential method is rarely used. The differences between the average angle, the minimum curvature, and the balanced tangential methods are so small that any of the methods could be used for calculating the trajectory. Several calculation methods are summarised in an excel worksheet for an overview (see Table 7).

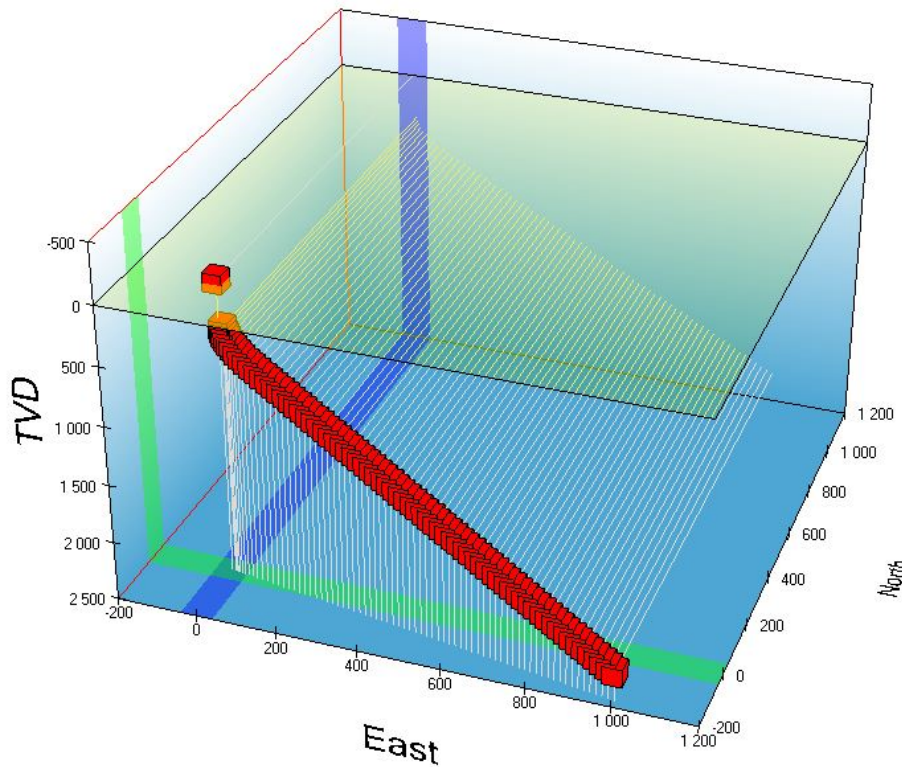

FIGURE 25: A 3D view trajectory of Well AB

TABLE 6: Comparison of the accuracy of various calculation methods

Case 1:	Well AA	
Direction:	Due north	
Survey interval:	240 m	
Rate of build:	3°/30 m	
Total inclination:	30° at 650 m	
Azimuth:	325°	
Calculation method	Total vertical depth (m)	North displacement (m)
Minimum curvature	233.50	51.15
Balanced tangential	226.75	49.77
Angle-averaging	231.82	50.88
Tangential	213.84	89.25

3.3.4 Drill string design (limitations)

The drill string is defined here as the drill pipes with tool joints and drill collars that reach from the rig down to the drill bit. The drill stem consists of the drill string and other components of the drilling assembly that includes the Kelly, subs, stabilizers, reamers as well as shock absorbers, and drilling jars used in certain drilling conditions. The lowermost part of the drill string with the drill collars etc. is called the bottom hole assembly (BHA) (Figure 26).

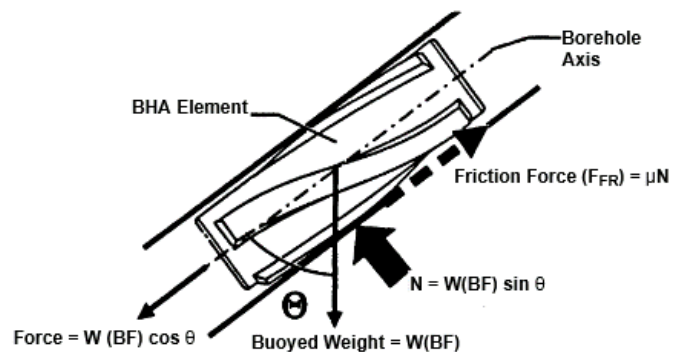

FIGURE 26: BHA weight for rotary assemblies

TABLE 7: Excel worksheet, comparison between calculation methods

Well AA								
Measured depth	Hole dev	Dev azi	Avg. tangential method			Balanced tangential method		
			North	East	TVD	North	East	Tvd
0	0	325	0	0	0	0	0	0
380	3	325	8.18	-5.72	379.87	8.17	-5.72	379.74
410	6	325	10.10	-7.07	409.78	10.10	-7.07	409.64
...
2510	30	325	832.23	-508.33	2247.20	832.21	-582.72	2246.98
Measured depth	Hole Dev	Dev Azi	Minimum curvature			Radius of curvature		
			North	East	TVD	North	East	TVD
0	0	325	0	0	0	0	0	0
380	3	325	8.17	-5.72	379.83	0	0	379.74
410	6	325	10.10	-7.07	409.73	0	0	409.64
...
2510	30	325	832.22	-582.73	2247.13	0	0	2247.33
Well AB								
Measured depth	Hole dev	Dev azi	Avg tangential method			Balanced tangential method		
			North	East	TVD	North	East	TVD
0	0	100	0	0	0	0	0	0
380	3	100	-1.73	9.83	379.87	-1.73	9.83	379.74
410	6	100	-2.74	12.14	409.78	10.10	-7.07	409.64
...
2510	30	100	-176.42	872.78	2247.20	-176.42	1000.50	2246.98
Measured depth	Hole dev	Dev azi	Minimum curvature			Radius of curvature		
			North	East	TVD	North	East	TVD
0	0	100	0	0	0	0	0	0
380	3	100	-1.73	9.83	379.83	0	0	377.84
410	6	100	-2.14	12.15	409.73	0	0	407.82
...
2510	30	100	-176.42	1000.52	2247.13	0	0	2247.33

There are four basic requirements which must be met when designing a drill string:

- The burst, collapse and tensile strength of the drill string components must not be exceeded;
- The bending stresses within the drill string must be minimised;
- The drill collars must be able to provide all of the weight required for drilling; and
- The BHA must be stabilised to control the direction of the well.

In order to design the BHA to hit the bottom target, the following will be determined:

- Length of BHA necessary for a desired weight on bit (WOB);
- Length of drill pipe and drill collar to be used with a specific bottom hole assembly; and
- Design of a drill string for the conditions specified.

Design parameters:

Depth	= 2510 m
Hole size	= 8½"
Mud weight	= 1.08
Desired MOP	= 30.10 ³ daN = 30 600 kg
Safety factor in collapse	= 1.15
Size and weight of drill collars	= (6½ in. x 2¼ in.) = 147.92 kg/m
Weight on bit (WOB)	= 10 tonnes

The buoyancy factor needs to be calculated:

$$BF = \frac{W_s - W_m}{W_s} \quad (34)$$

where BF = Buoyancy factor;
 W_s = Weight of steel (7.85 g/l); and
 W_m = Weight of mud or completion brine fluid (1.05 g/l).

$$BF = \frac{7.85 - 1.05}{7.85} = 0.8662$$

Then the length of drill collar necessary for 10 tons of WOB:

$$L(DC) = \frac{10^5 WOB}{\cos(\alpha) * F_{PN} * P_{DC} * k} \quad (35)$$

where $L(DC)$ = Length of drill collars (m);
 WOB = Maximum weight on bit (t);
 α = 3° (hole angle from vertical);
 F_{PN} = 85% (neutral point position as percentage of the total drill collar string length);
 P_{DC} = Weight per meter of drill collar (kg/m); and
 k = Buoyancy factor.

$$L(DC) = \frac{10 * 10^5}{(0.998) * (85) * (147.92) * (0.8662)} = 92 \text{ m} \approx 10 \text{ DC}$$

Pipe size, weight and grade used are:

$4\frac{1}{2}$ " = 20.00 lb/ft, Grade g105, IEU, Range 2 (9.1 m);
 P_{DP} = 29.76 kg/m (weight per meter of drill collar);
 T_{e1} = $120 \cdot 10^3$ daN (tensile yield strength); and
 P_{ct} = 30 000 kPa (limit collapse pressure).

No drill pipes are used to apply weight on the bit. All the weight comes from the drill collars, 85% of the DC weight, as shown before. Table 8 summarizes the BHA design for a depth of 2510 m.

TABLE 8: Dimensions and weight for the BHA

Hole size (inches)	Bit sizes (Inches)		Weight on bit (kg)	Length of drill collar (m)	Weight of BHA for tangent section (kg)
$8\frac{1}{2}$ "	$6\frac{1}{2}$ " OD	$2\frac{1}{4}$ " ID	10000	92	130258.18

3.4 Scenario of vertical drilling

Directional drilling is the same as vertical drilling until the kickoff point at 350 m depth, at which depth the well is deviated gradually from the vertical (Figures 27 a and b). Vertical well drilling operations differ from directional well drilling operations. A non-exhaustive comparison between these two types of drilling methods highlights the main technical aspects such as engineering, environmental issues, subsurface data collection, and costs (Table 9). Three main points can be taken from this correlation:

- A target depth of 2000 m has been chosen in this comparison as an example, which is within the depth range suggested by REI for directional drilling. This short comparison shows that each type of drilling has its pros and cons. The costs of drilling alone are clearly higher for directional drilling, due to the longer length of the well to reach the target. If the costs of survey tools and equipment are added, then directional drilling may be up to 30% more expensive than vertical

TABLE 9: Non-exhaustive comparison between directional and vertical drilling for a target at a depth of 2000 m as example; note that the differences between the two drilling types are presented in italics

Well features, data collection, and others	Directional drilling	Vertical drilling
Engineering and environmental issues	Needs casing	Needs casing
	<i>140 t. hook load of rig</i>	<i>80-100 t. hook load of rig</i>
	<i>Pad size: 12,140-24,280 m²</i>	<i>Pad size: 4,046-12,140 m²</i>
	Multiple well pads and side tracking	Multiple well pads and side tracking
	<i>Accessing target from distance, therefore, smaller well pads and sites constructions with reduced cost of water well supply, well track profile planning, rig shifting, steam gathering system, access roads, pipelines, site rehabilitation, brine disposal, etc., resulting in less environmental issues</i>	<i>Accessing target precisely from above, therefore, more well pads and construction sites with higher cost of water well supply, well track profile planning, rig shifting, steam gathering system, access roads, pipelines, site rehabilitation, brine disposal, etc., resulting in more environmental issues</i>
	<i>More expensive tools and supervision</i>	<i>Less expensive tools and supervision</i>
Length of time for drilling	45 m/day	45 m/day
Well length to reach a target at 2000 m	<i>~ 2310 m</i>	<i>2000 m</i>
Subsurface data collection	Alteration/mineral assemblage	Alteration/mineral assemblage
	Salinity	Salinity
	Rock permeability	Rock permeability
	Fractures/broken zones	Fractures/broken zones
	Heat	Heat
	Stress and strain	Stress and strain
	Earthquake location	Earthquake location
Further studies to locate targets	<i>Available</i>	<i>Required</i>
Permit	<i>No drilling permit needed inside Lava Lake</i>	<i>Drilling permit needed inside Lava Lake</i>
Unit cost of drilling without tools, equipment, and supervision	<i>~ 1500-2000 \$/m</i>	<i>~ 1500-2000 \$/m</i>
Total drilling cost without tools, equipment, supervision, and site constructions	<i>3,465,000-4,620,000 \$</i>	<i>3,000,000-4,000,000 \$</i>

drilling. On the other hand, the costs of multiple well pads can change the outcome. A detailed cost analysis of multiple well pads is needed to see the total costs of each type of drilling and which one would be financially sound.

- From an environmental view point, the constructions related to multiple well pads, as well as the water waste, chemical products, and mud from the wells are major concerns. Due to these main concerns, drilling in the Lava Lake is not permitted at this point. Considering that vertical drilling must be carried out above the target(s), i.e. inside the Lava Lake for potential targets there, the

existence of the permit is an issue that has to be dealt with should vertical drilling be revealed as the preferred choice for targets inside the Lava Lake.

- From geological and geophysical points of view, information regarding the subsurface can be obtained equally from directional and vertical drilling (Table 9), but the ultimate choice depends on the total costs for each type of drilling. As to the well production, cases are known worldwide where directional drilling has been 2.5-7 times more productive than vertical drilling. This higher production rate may partly be due to the fact that directional drilling intersects several fractures or a wider broken zone with higher permeability (Figure 27a). But as indicated, pre-feasibility studies are not precise enough to accurately locate potential targets for vertical drilling outside or inside the Lava Lake of Fialé. Considering that knowledge of the dip direction of a target fracture is critical for vertical drilling (Figure 27b), further geological studies are required to estimate the potential fracture targets as well as the risks, especially concerning seismically active fractures such as the NNW fault in the western part of Fialé.

Due to a lack of further geological and geophysical studies, at this stage the best suggestion for vertical drilling would be to aim at the same targets as recommended by REI for directional drilling (Figure 28), given that permission can be obtained to drill inside the Lava Lake. To offer more choices in the site of well AA, a few fractures have been reported from the pre-feasibility study (Khodayar, 2008). According to that study, these fractures were identified from aerial photographs only. Their exact locations on maps may be more or less displaced due to distortions between the old aerial imageries and the old topographical maps on which the fractures were reported at the time of that study. In general, vertical drilling could be located on both sides of an individual fracture to obtain its dip direction, or at fracture intersections. It is important to keep in mind that the above suggestion is, in no way, a thorough site selection of targets for vertical drilling; further studies are necessary.

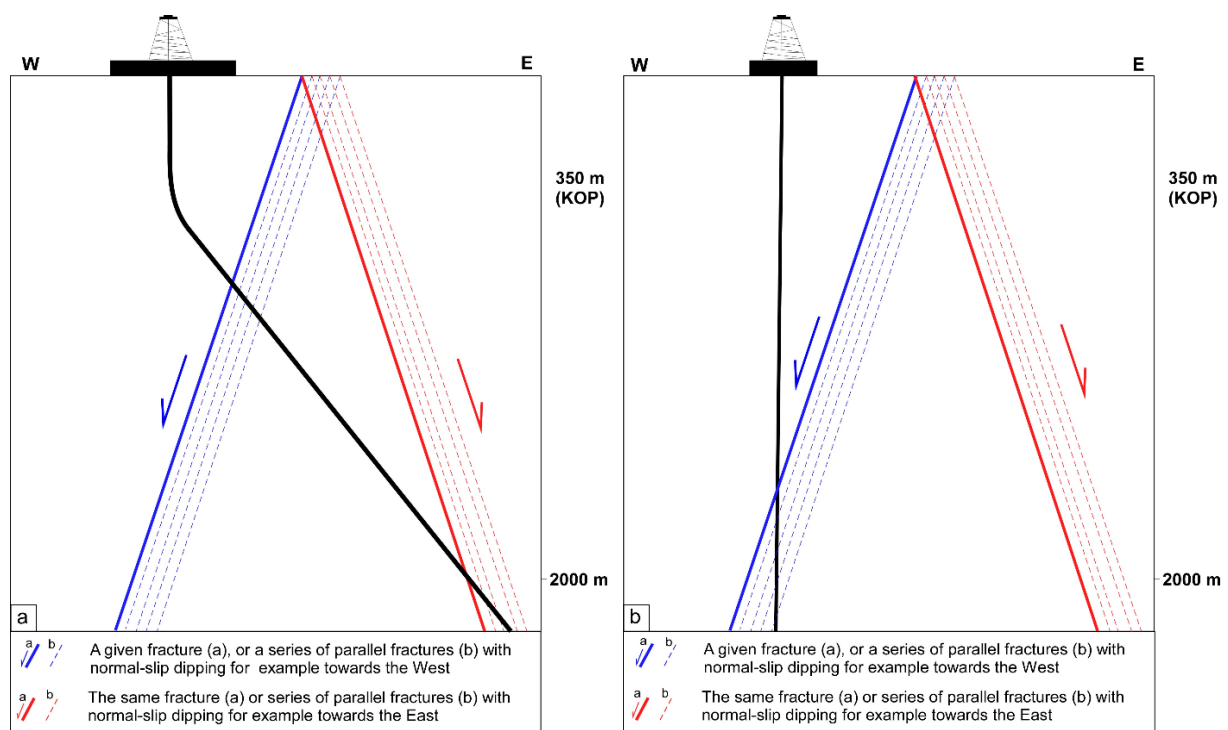

FIGURE 27: Directional and vertical drilling

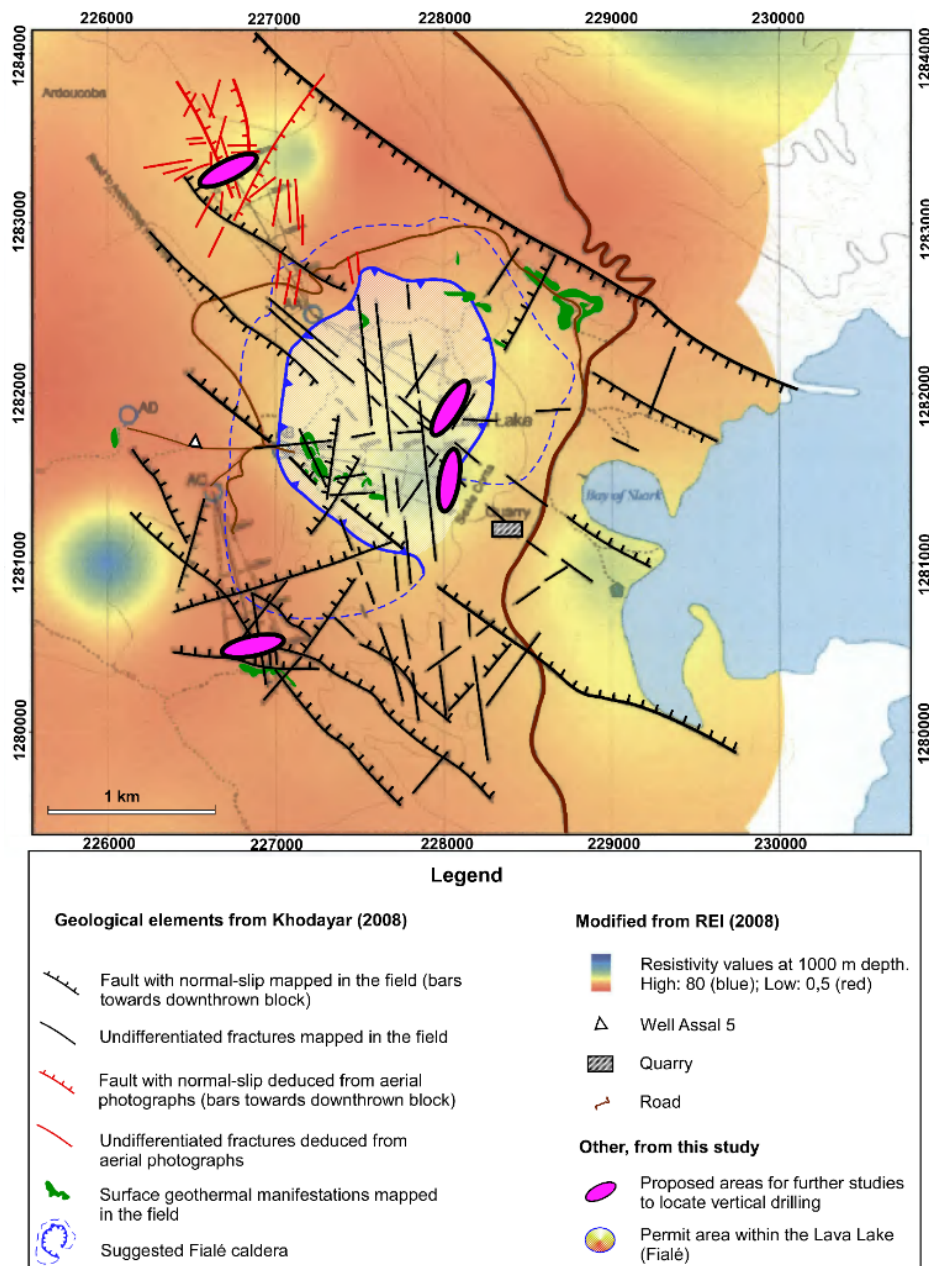

FIGURE 28: Proposed areas requiring further studies to locate vertical drilling inside and outside of the Lava Lake (Fialé)

4. CONCLUSIONS AND RECOMMENDATIONS

Based on the calculations in the case studies of directional drilling, the build and hold program is the most attractive approach for the production wells in Asal Fialé. Simple two-stabilizer building assemblies could be used with optimal WOB. Because the BHA could always be building the angle, the effects of the formation forces could be controlled easily by adjustment of the second stabilizer, either closer to or farther from the lead stabilizer. Drilling through the abrasive sandstone at the base of the cretaceous would require 3-point roller reamers instead of stabilizers. These reamers would also be necessary in hard limestone. To drill through these wells, regular spiral or straight-bladed stabilizers could be used. The risk in the build and hold program is that the build might close in the harder limestone and motors would be needed to complete the hole.

The foregoing approaches are only a few of the possibilities that could be deduced from the principles presented in the report. There is no absolute way of drilling a directional well. However, there are better, optimal ways to drill any well (good planning and careful selection of the bit, mud system, etc.) that should minimize the risks. Assuming the previous results (trajectory and survey calculations), with REI's proposal to make the KOP at 350 m, it is proposed here that the kick off point should be at least 30 meters below the casing shoe. Thus, all directional wells in the future in Asal should have a kickoff point at 430 m depth at least with a 400 m intermediate casing.

Vertical drilling is another option. Based on the results of the pre-feasibility studies, the best suggestions for vertical drilling at this stage are to drill down to 2000 m into the targets recommended by REI (2009) (Figure 28). Such vertical exploration wells would be best placed on both sides of individual fractures or at their intersections. For potential targets inside of the Lava Lake of Fialé, a permit has to be obtained. However, additional geological and geophysical surveys are required to accurately select the targets for vertical drilling. Such studies should also estimate the risks related to seismic faults, in particular for those target fractures inside the Lava Lake where shallow magmatic bodies could be present at depth. Drilling inside the Lava Lake would have the advantage of determining whether that area as a whole is indeed less saline than the two other target areas suggested by REI (Figure 17).

The concluding remarks and recommendations can be summarised as follows:

- All subsurface information can be gathered by either vertical or directional drilling.
- The choice of drilling method depends mostly on the cost, for which a thorough cost estimate of: (a) survey tools and equipment for directional drilling, (b) multiple well pads, and (c) drilling, will determine whether vertical or directional drilling is the better option.
- For directional drilling, no further studies or permits are required at this stage. But if vertical drilling is favoured, then further studies are required to understand and choose the targets before drilling, and a permit must be obtained to drill inside the Lava Lake of Fialé.

ACKNOWLEDGEMENTS

The success and final outcome of this project required a lot of guidance and assistance from many people and I am extremely fortunate to have gotten this for the completion of my project work. That I have done this is only due to such guidance and assistance and I will not forget to thank them. I wish to thank Dr. Ingvar B. Fridleifsson, the outgoing director of the UNU Geothermal Training Programme, and Mr. Lúdvík S. Georgsson, the present director of the UNU GTP, for their organization of the training and the follow up of our learning. Many thanks to Mr. Ingimar Gudni Haraldsson, Ms. Málfríður Ómarsdóttir, Mr. Markus A. G. Wilde, and Ms. Thórhildur Ísberg for their support and help in the programme. I wish also to thank my supervisors for their help in different parts of my report: Hannes Sverrisson (from Mannvit) for directional well design, Sverrir Thórhallsson (from ÍSOR) for bottom hole assembly, and Dr. Maryam Khodayar (from ÍSOR) for vertical drilling, and the insightful discussions, valuable advice, and their support during the whole period of the study, and especially for their patience and guidance during the writing process. I am grateful to the UNU Fellows for the wonderful time we had together during this 6 months.

I hope my friends and colleagues, too numerous to thank individually, will forgive me for not compiling a huge list here.

Lastly, I thank almighty, my parents, brother, and sisters for their constant encouragement without which this assignment would not be possible. To the love of my life, Samia!

Above all, I praise God, the almighty for providing me this opportunity and granting me the capability to proceed successfully.

REFERENCES

- Aquater, 1989: *Djibouti geothermal exploration project, Republic of Djibouti, final report*. Aquater, Italy, report, 159 pp.
- Árnason, K., and Flóvenz, Ó.G., 1995: Geothermal exploration by TEM-Soundings in the Central Asal Rift in Djibouti, East Africa. *Proceedings of the World Geothermal Congress 1995, Florence, Italy*, 933-938.
- Árnason, K., Eysteinnsson, H., and Vilhjálmsson, A.M., 2008: *The Asal geothermal field, Djibouti. Geophysical surface exploration, 2007-2008*. ÍSOR - Iceland GeoSurvey, report ISOR-2008/019, prepared for REI (confidential), 74 pp.
- Árnason, K., Björnsson, G., Flóvenz, Ó.G., Haraldsson, E.H., 1988: *Geothermal resistivity survey in the Asal rift, volume 1: Main text*. Orkustofnun, Reykjavík, report S-88031/JHD-05, prepared for the UND-OPS and ISERST, 48 pp.
- Baker Hughes INTEQ, 1995: *Drilling engineering workbook. A distributed learning course*. Baker Hughes INTEQ Inc., 410 pp.
- Bourgoyne, A.T., Millheim, K.K., Chenevert, M.E., and Young, F.S. Jr., 1991: *Applied drilling engineering*. SPE Textbook Series, 2, 502 pp.
- French Oil and Gas Industry Association, 1990: *Directional drilling and deviation control technology*. Editions technic, Paris, France, 137 pp.
- Gabolde, G., and Nguyen, J.P., 1991: *Drilling data handbook*. Gulf Publishing Co., Houston, TX, United States, 542 pp.
- Gaulier J.M., and Huchon, P., 1991: Tectonic evolution of Afar triple junction. *Bull. Soc. Géol. France*, 126, 451-464.
- Inglis, T.A., 1987: *Directional drilling*, vol. 2. Graham & Totman, Ltd., London, 260 pp.
- Khodayar, M., 2008: *Results of the 2007 surface geothermal exploration in the Asal Rift and transform zones, Djibouti: Tectonics and geothermal manifestations* (revised version, May 2008). Iceland GeoSurvey, report ÍSOR-2008/008, prepared for REI (confidential), 81 pp + 5 maps.
- REI, 2008: *Drilling and testing of geothermal exploration wells in the Assal Area, Djibouti: Environmental management plan*. Reykjavik Energy Invest, report REI-2008/Assal 1, 58 pp.
- REI, 2009: *Geothermal pre-feasibility study in the Asal Rift, Djibouti: Project status after completions of surface exploration studies and environmental impact assessment*. Reykjavik Energy Invest, confidential report, REI-2008, 20 pp.
- Saemundsson, K., 1988: *Djibouti geothermal project. Analysis of geological data pertaining to geothermal exploration of Asal rift*. UNDP, 18 pp.
- Sperry-Sun, 2001: *Directional surveying fundamentals*. Sperry-Sun Training Department, a Halliburton Company, Houston, TX, United States, 108 pp.
- Varet, J., 1978: *Geology of central and southern Afar (Ethiopia and Djibouti Republic)*. Centre National de la Recherche Scientifique, Paris, France, 124 pp.

Virkir-Orkint, 1990: *Djibouti geothermal scaling and corrosion study, final report*. Virkir-Orkint Consulting Group Ltd, Iceland, report prepared for Electricité de Djibouti, 273 pp.

APPENDIX I: Expected lithological profiles and designs for Wells AA and AB, Asal, Fiale

